

INSTRUCTION SHEET

Tillotson Carburetor - Model TC

General Exploded View

The general design and parts shown will vary to individual units covered on this instruction sheet.

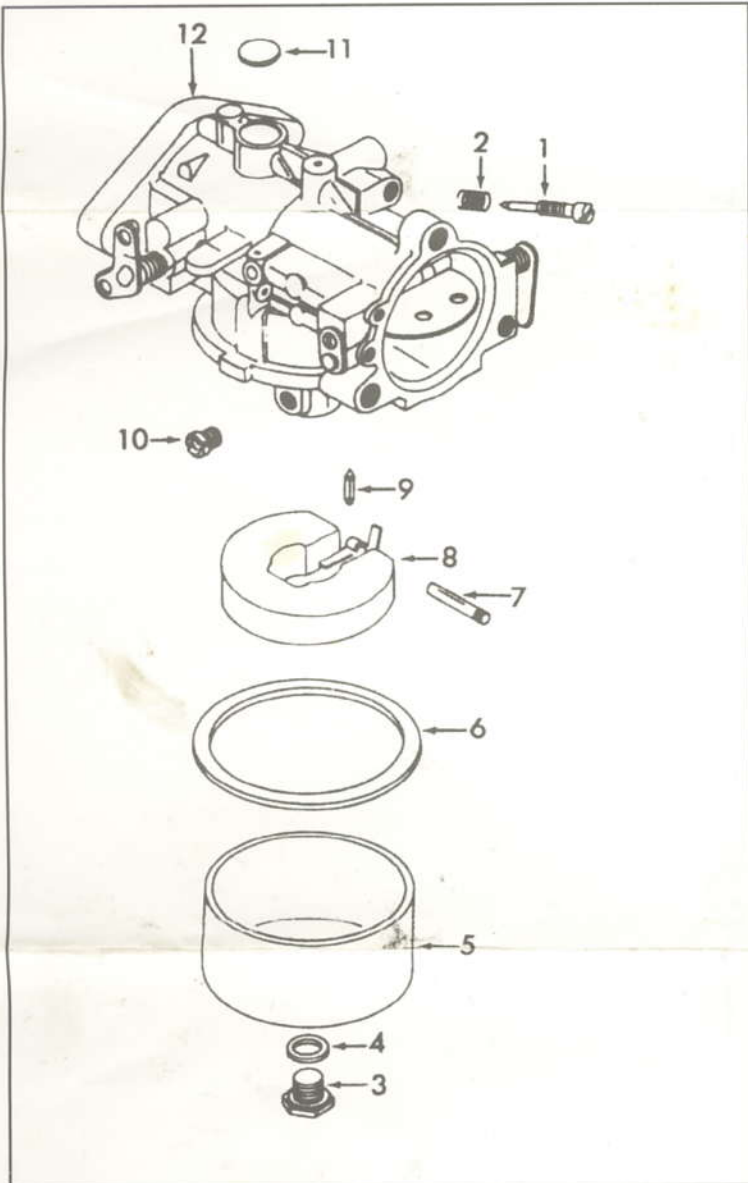

Disassembly

Use the exploded view as a guide. The numerical sequence may generally be followed to disassemble unit far enough to permit cleaning and inspection.

Note: To remove welch plug (11) carefully drill hole in plug and pry out with suitable tool.

Nomenclature

Ref. No.

1. Needle - Idle Adjusting
2. Spring - Idle Adjusting Needle
3. Screw - Fuel Bowl Retaining
4. Gasket - Fuel Bowl Screw
5. Bowl - Fuel
6. Gasket - Fuel Bowl
7. Pin - Float Lever
8. Float & Lever Assembly
9. Needle Assembly
10. Jet - Main Fuel
11. Plug - Welch
12. Main Body Assembly

Cleaning

Cleaning must be done with carburetor disassembled. Soak parts long enough to soften and remove all foreign material. Use a carburetor cleaner, lacquer thinner or denatured alcohol. Wash off in suitable solvent. Blow out all passages in the castings with compressed air and check carefully to insure thorough cleaning of obscure areas.

Caution: Do not soak float or rubber parts in cleaning solvents.

Reassembly

Reassemble in reverse order of disassembly. **Note:** Special instructions and adjustments.

Special instructions

Carburetor body inverted, measure from gasket surface to farthest edge of float.

Caution: Do not exert pressure on resilient needle valve.

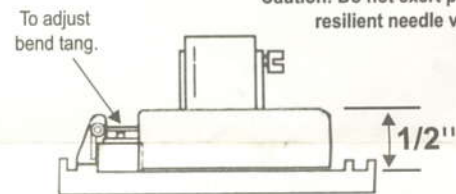

Dry Float Level Adjustment

Carburetor body in normal position, float hanging freely. Measure from gasket surface to farthest edge of float.

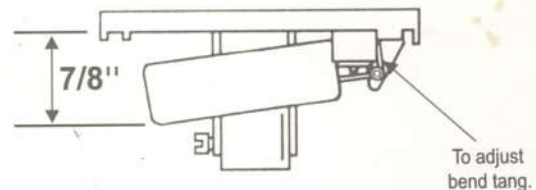

Float Drop Adjustment

Idle adjusting needle (1) - turn in until lightly seated, then back out 1 1/2 turns.