

# Elite REEL SYSTEMS

## SIGNATURE INGROUND REEL SYSTEM

For solar covers up to 20' x 40'

### PLACEMENT ON DIFFERENT SHAPE POOLS:

Before assembling the reel, determine its best location on the pool. The end of the pool is most often the preferred location. On some pools, a mid-point location may be required to avoid diving boards and ladders. Blanket may be folded in to avoid using a larger reel.

### HELPFUL HINTS:

1. Always place white protective cover over blanket and secure.
2. Make sure cover is properly trimmed away from pool's edge.
3. If tubing is sagging, refer to "Assembly of Tubing".
4. If your pool is kidney shaped, you may only need 3 straps to attach to tubing. Refer to "Preferred Reel Placement".
5. You may cut down one of the smaller tubes to custom fit the reel to your pool width. This does not void the warranty. Overall tube length should be 18" longer than your pool's width.



Place reel at widest point. Fold blanket in if required.

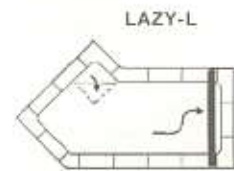

Place reel at square end and fold "L" over.

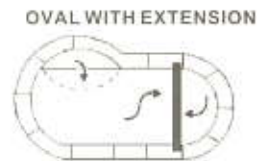

Options: Fold extension in, or use wider reel at widest point

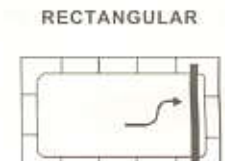

Place reel at either end.

### DIAGRAM OF REEL

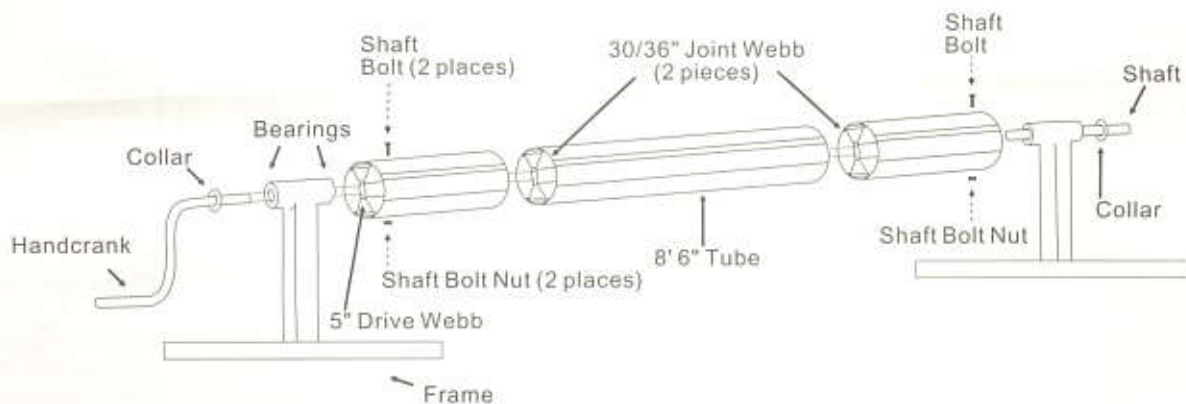

### SIGNATURE PARTS LIST

Part #	Description	Qty	Part #	Description	Qty
3017	Frame	2	3061	Bearing	4
5006	9" Shaft	1	3060	Collar	2
5005	Handcrank	1	3063	Shaft Bolt	2
7010	Ingd. Cover Kit	1	3067	Shaft Bolt Nut	2
3030	5" Drive Webb	2	3066	Tek Tube Fastener	40
			2017	Frame Cap (Black)	4

### Aluminum Tubing UNIQUE TO EACH REEL SIZE

Pool Width 14' - 18'			Pool Width 20'		
Part #	Description	Qty	Part #	Description	Qty
3014	6'6" Alum. Tube	3	3014	6'6" Alum. Tube	2
3024	30" Joint Webb	2	3029	8'6" Alum. Tube	1
			3036	36" Joint Webb	2

### TOOLS REQUIRED

- 1) Power Drill w/ Phillips Bit    2) Hex Socket Wrench    3) Allen Wrench    4) Rubber Mallet

## I. ASSEMBLY OF FRAME

1. Press each bearing into the round tube at the top of the frame. Use rubber mallet to seat the bearings into place.
2. There are (2) bearings per frame. One for each side of frame. Put bearings into both frames.
3. Place 2" caster through pre-drilled hole in bottom of frame. Attach locking nut and tighten down. Attach (2) casters to each frame.

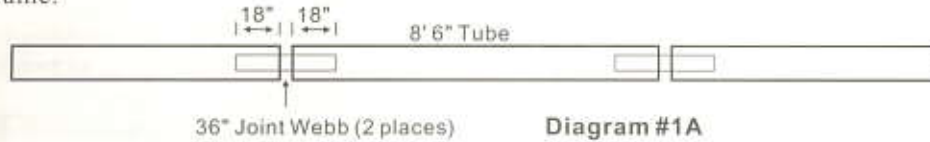

## II. ASSEMBLY OF TUBING

- \* **You may cut down one of the smaller tubes to custom fit the reel to your pool width. This will not void your warranty. Use a hacksaw on aluminum tube.**
- \* **Rule of thumb: Overall length of tubing should be 18" longer than your pool width. You want the cover to be as close to the metal frames as possible.**

1. You have (3) aluminum tubes. When complete, you should have 3 tubes connected together in (1) long tube. **Depending on which reel size you purchased is how long your tubes are.** However, the 8'6" tube is common to most sizes. This 8'6" tube goes in the middle of your tube assembly. The (2) shorter tubes attach to each end of the 8'6" tube. (See Diagram #1A)
2. Lay all (3) tubes down on the ground. Place the 8'6" (or 6'6") tube in the middle with each of the other (2) shorter tubes on each side.
3. Take the 30" Joint Webb (36" Joint Webb if 20 FT. Reel) and slide it halfway into the 8'6" tube. **When finished, half of the Joint Webb will be extended out of the 8'6" tube.** (See Diagram #1B) When installed properly, the Joint Webb should slide into the tube but should not be able to rotate inside the tube. (See Diagram #1C)
4. To fasten Joint Webb to the tube (See Diagram #1C & #1D), measure 2" on the tube and attach (1) Tek screw to each leg of the Joint Webb. The tube has (4) small indentations which line up with the (4) Joint Webb legs. Use these tube indentations to insure proper position of the (4) screws. Make sure the Tek screw goes thru the vertical part of the Joint Webb Leg. This will insure that the screw has the maximum amount of threads into the Joint Webb leg. **When finished, you should have used (4) Tek screws and they have been attached to each Joint Webb Leg.** (See Diagram #1C)
5. Now measure 12" on the tube and attach (4) more Tek screws through the tube into each Joint Webb Leg. **When finished, you should have (4) screws at 2" and (4) screws at 12".**
6. Now slide the exposed part of the Joint Webb into the 2nd tube (See Diagram #1A). Follow instruction #4 and #5 on attaching the Joint Webb to the tube. After attaching the (2) tubes together, then proceed to attach the middle tube to the 3rd tube by following steps 3-5.
7. You should have all (3) tubes attached securely with the (2) Joint Webbs. **It is important that the tubes are fastened together correctly to eliminate sagging. If sagging occurs, attach more Tek screws at the 2" measurements where the tubes join together. This will strengthen the tube assembly and eliminate sagging.**

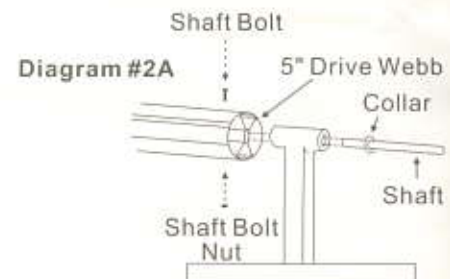
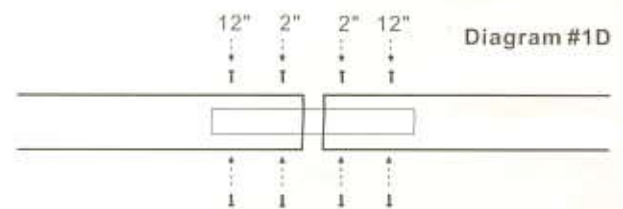
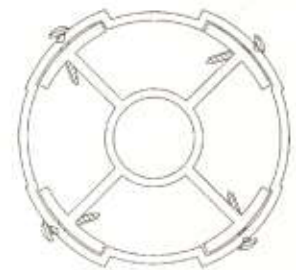
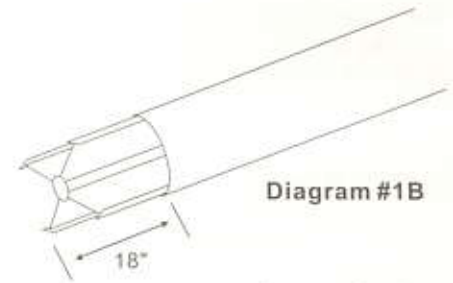

## III. ASSEMBLY OF SHAFT / HANDCRANK TO 5" DRIVE WEBB

1. Take the 9" shaft (#5006) and slide it into the 5" Drive Webb. Align the drilled holes in each piece and connect with the shaft bolt and locking nut. Tighten down firmly.
2. Now slide the shaft (with Drive Webb) through the bearings in the frame. Push the shaft so that it's extended 1" out of the frame. (See Diagram #2A).
3. Attach zinc plated collar (#3060) to the 1" extended shaft. Place the collar next to the frame and tighten set screw on collar.
4. Now take the handcrank and slide it through the collar. **(DO NOT TIGHTEN COLLAR)**
5. Take handcrank and slide it through the bearings in the frame. (See Diagram #2B)
6. Slide 5" Drive Webb onto handcrank and align the drilled holes in each piece. Take shaft bolt and slide through holes and attach locking nut. Tighten down firmly.
7. Place the collar next to frame and tighten set screw on collar.
8. You should now have the shaft / 5" Drive Webb attached to one frame and the handcrank / 5" Drive Webb attached to the other frame.

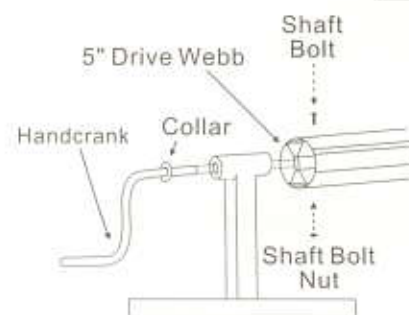

#### IV. ASSEMBLY OF FRAMES TO ALUMINUM TUBING.

1. Take the frame with the shaft / 5" Drive Webb. Align the 5" Drive Webb with one end of the aluminum tube. Slide the 5" Drive Webb into tube until its flush with tube end.
2. Now take the frame with Handcrank / 5" Drive Webb. Align the 5" Drive Webb with the other end of aluminum tubing. Slide the 5" Drive Webb into tube until its flush with tube end.
3. Take (4) Tek tube fasteners and attach tubing to 5" Drive Webb with shaft. (Attach per Diagram #3) Measure 1" in from end of tubing and attach (2) Tek Fasteners through tube and into leg of 5" Drive Webb. **Make sure the Tek Screws are 180° apart on tube.** Now measure 4" in from end of tubing and attach (2) more Tek Screws. Attach Tek Screw through tube into leg of 5" Drive Webb. **Make sure Tek Screws are 180° apart.**
4. Repeat Step #3 to attach 5" Drive Webb with Handcrank to aluminum tube. (See Diagram #4)
5. You should now have the reel assembled and ready to attach to the cover.

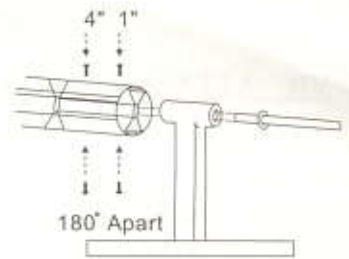

DIAGRAM #3

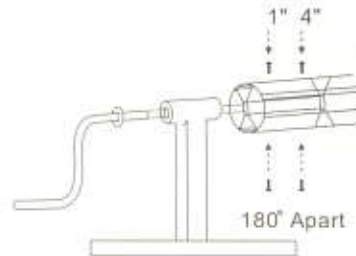

DIAGRAM #4

#### V. CONNECTING THE COVER TO THE REEL

(See Diagram #5)

1. Select a location suitable for pool cover removal, usually on the pool end without steps. **Refer to preferred reel placement which is at beginning of instructions.** Make sure the pool cover is trimmed properly. The tube should be positioned perpendicular to the center line of the pool as in Diagram #5. **PROPER ALIGNMENT BETWEEN POOL COVER AND THE TUBE IS CRITICAL!** Whether your pool is rectangular or irregular in shape, the straps must be placed and installed so that there is equal pull on all straps at the same time to prevent misalignment of the cover.

#### VI. ATTACH COVER PLATES TO BLANKET

(See Diagram #6)

1. Starting at one side of the pool cover, position a set of plates (male and female) with the large center slot at the location of the first strap and at least 2" from any edge of the pool cover.
2. With a sharp instrument, using the female plate as a guide and with the raised ridges facing **DOWNWARD**, punch 3 holes through the plate and cover. The holes must be as wide as the holes in the plate.
3. Place a male plate under the cover directly beneath the female plate.
4. Insert the 2 snaps through the cover and snap together. If the plates do not snap into position with normal force, remove excess cover material.



DIAGRAM #5

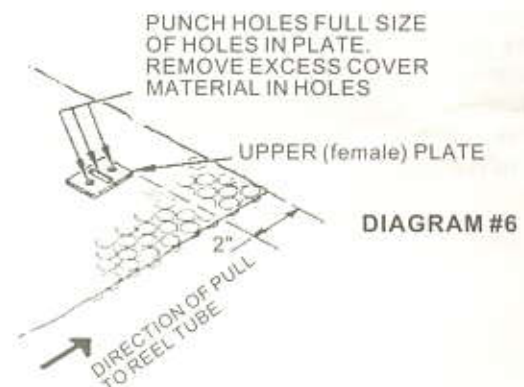

DIAGRAM #6

## VII. ATTACH STRAP/STRAP BUCKLE

(See Diagram #7A, 7B & 7C)

1. With the ridged crossbar on the strap buckle up, slide the buckle onto the strap from the end opposite the velcro.
2. Position the buckle at least 24" up from the strap end. Bring the strap underneath the pool cover and up through the center opening in the plate.
3. Thread the strap end back through the buckle.
4. Repeat process for each strap.

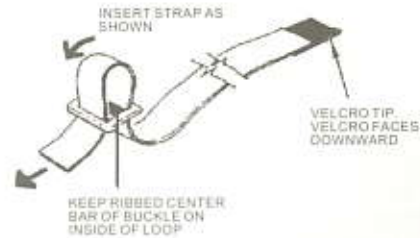

DIAGRAM #7A

## VIII. ATTACH VELCRO HOOK TO ALUMINUM TUBE

(Refer to Diagram #8)

1. Place the velcro end of the strap over the tube.
2. Standing behind the tube, pull the strap taut and align as straight as possible between the cover plate and the tube.
3. Remove adhesive backing from the velcro tab and place it firmly into position on top of the tube. Tube must be dry and free from grease or dirt.
4. Repeat procedure for each strap, keeping the velcro adhesive tabs in a line along the top of the tube.
5. Use the buckles to adjust each strap so all provide equal tension on the tube. This is necessary for proper alignment!

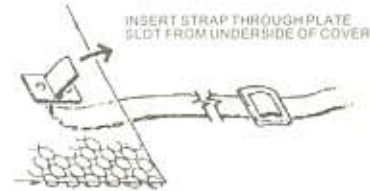

DIAGRAM #7B

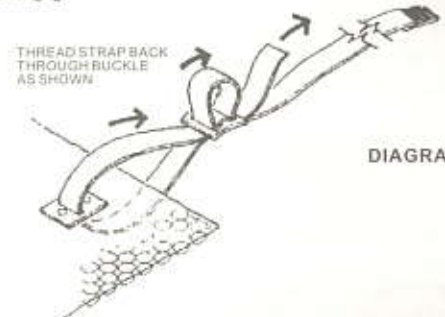

DIAGRAM #7C

## IX. OPERATING INSTRUCTIONS

(Refer to Diagram #9 & 10)

1. Place reel in a straddling position 2' in from the end of the pool.
2. Turn Handcrank slowly. The straps will move the cover away from back edge of pool and fold over itself toward the tubing.
3. Continue turning the Handcrank the cover will continue to fold over itself, eventually going underneath the tube, then up, over and onto the tube.
4. You may have to straighten/unwrinkle the cover as it wraps onto the tube. The smoother the cover wraps onto the tube, the easier the unrolling of the cover when putting cover back onto the pool.
5. Continue rolling cover onto the reel. Keep cover seams straight and avoid cover misalignment.
6. Suggestion: If you move your reel away after cover roll up, mark the position of the bases on your pool deck. This will assure proper roll up the next time you use your reel system.
7. Thank you for purchasing you ELITE reel system. We hope you'll enjoy it for many years.

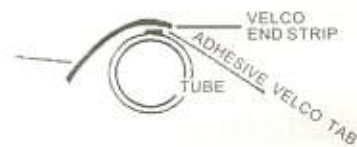

DIAGRAM #8



DIAGRAM #9

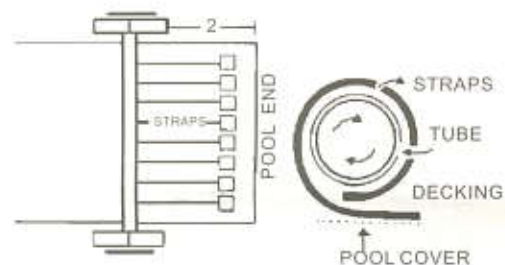

DIAGRAM #10