

DREMEL® Chain Saw Sharpening Attachment Kit

Owner's Manual - Model 1453

CHAIN SAW SHARPENING WARNINGS

⚠ WARNING Read and understand these instructions and the chain saw manual for complete details for sharpening and use of the chain saw. Failure to follow all instructions and warnings may lead to injury.

⚠ WARNING Disconnect electrical plug or spark plug lead from the power source. Accidental start up could cause serious personal injury.

⚠ WARNING Wear eye protection and dust mask. Grinding action will cause dust and sparks.

⚠ WARNING Teeth of chain must be sharpened equally and evenly. Uneven teeth can cause the saw to kickback and excessive wear to the bar.

Your new chain saw sharpening attachment kit will fit on Dremel rotary tool models 275, 285, 395, 398, 850 and 780. When attached to a Dremel rotary tool, the Chain Saw Sharpening attachment will sharpen nearly all popular sizes of chain if you follow these simple instructions.

ASSEMBLY OF CHAIN SAW SHARPENING ATTACHMENT

Because there are different sizes and types of chains used on different saws, your new sharpener must be assembled to suit your particular chain. To do this:

1. First determine the size and pitch of your saw chain. Refer to your chain saw owner's manual, your chain saw instruction manual or contact the chain manufacturer for this information.
2. Refer to the chart below for the correct grinding stone.

Chain Size / Pitch	Grinding Wheel Size (Diameter)	Grinding Wheel Color	Grinding Wheel Catalog No.	Guide Gauge
1/4" PITCH	5/32"	Blue	453	Side 1
3/8" PITCH	7/32"	Pink	455	Side 1
3/8" PITCH LOW PROFILE (LP)	5/32"	Blue	453	Side 1
.325" PITCH	3/16"	Orange	454	Side 1

3. When you have determined the correct grinding stone for your chain from the chart, assemble attachment by screwing the guide (B) and appropriate number of spacers (C) to the clamp (D) using the two screws (A), as shown in figure 1.

- If using the 7/32" diameter (pink) grinding stone, assemble **both spacers** between the guide and the clamp.
- If using the 3/16" diameter (orange) grinding stone, assemble with **only one spacer** between the guide and the clamp.
- If using the 5/32" diameter (blue) grinding stone, **no spacers** are needed.

4. Securely mount the correct grinding stone in your tool with approximately 1/4" of the shank exposed between the chuck cap and the stone (Figure 2). Use the rotary tool wrench to securely tighten the chuck cap.

5. Remove the housing cap from your rotary tool and screw on the chain saw sharpening attachment (Figure 3).

6. Using the appropriate side of the gauge (E) (see above chart), check to see if the guide (B) is properly positioned in respect to the grinding stone (F). The gauge must be flush with the corner (G) of the guide while making contact with the grinding stone (Figure 4).

If the guide is not properly positioned, use a screwdriver (the end of the gauge has a screwdriver (H) on it) to loosen the two guide mounting screws (A) enough so the guide can be moved (I). It has elongated holes to allow for adjustment. Using the appropriate side of the gauge, adjust the guide so it is properly positioned in respect to the grinding stone and tighten the screws.

SHARPENING THE CHAIN

1. Set your saw on a flat, solid surface so it will not slip while you are sharpening the chain. The chain tension should be adjusted as specified in the Chain Saw Owner's Manual. If it is too loose, the teeth will move, resulting in a poor sharpening job.

Sharpening will be best accomplished if done on the flat of the saw bar – somewhere near the middle of the bar.

2. The saw should first be positioned so that you are looking at the side of the chain bar with the motor to your right. Cutter teeth on the far side of the chain are sharpened, from inside to outside, or away from you, as shown in Figure 5. The guide (B) should be laid flat on the tooth with the 30° index line (L) parallel with the chain. This index line should be aligned by eye with the chain.

Two or three light strokes are usually enough unless the cutters have been damaged. Sharpen all cutters equal. Start with the cutter with the most visual damage (i.e. nicks or gouges) and sharpen all cutters back equally. Do not remove excessive material as this only shortens the life of the chain.

Note: Sharpen cutter teeth (J) only, not the depth gauge (K).

3. When all of the teeth on the top of the bar have been sharpened, advance the chain using a glove or a rag to protect your hand, by pulling the chain toward the end of the bar. Repeat until all the teeth on the far side of the chain have been sharpened.

4. Turn the saw around so that you are looking at the side of the chain bar with the motor to your left. Sharpen the cutter teeth on the far side of the chain, from inside to outside, or away from you, as shown in Figure 6. The guide should be laid flat on the tooth with the 30° index line parallel with the chain.

Repeat the process above to sharpen all of the cutter teeth on the far side of the chain.

5. After your chain has been sharpened a number of times, you may find that it does not cut as fast as you feel it should. Each cutter on your chain has a depth gauge (K) just ahead of the cutting edge (J) that determines how big a bite it can take. To check for proper depth of the cut, lay a metal straight edge across the tops of the cutting edges, as shown in Figure 7, and check the dimension indicated. This dimension should be approximately equal to the thickness of the gauge furnished with your chain saw sharpening kit. If it is not, file or grind the chain depth gauge until the clearance is approximately equal to the thickness of the sharpening kit gauge. Be careful to maintain its shape. Do not remove more material than necessary or you will overload your saw. Also, be careful to keep this depth gauge setting uniform on all cutter teeth or you will not be able to make a straight cut.

ORDERING INFORMATION - refer to figure 8.

CODE NO.	PART NO.	DESCRIPTION
1	1453	Sharpening Attachment, Complete
2	990869	Gauge & 2 Spacers
3	453	5/32" Grinding Wheel, Blue
4	454	3/16" Grinding Wheel, Orange
5	455	7/32" Grinding Wheel, Pink

WRITE FOR CURRENT PRICES - NO C.O.D.'S

UNITED STATES
Dremel Service Center
4915 Twenty-First Street
Racine, WI 53406
Dremel Service Center
4631 E. Sunny Dunes
Palm Springs, CA 92264

OUTSIDE OF CONTINENTAL UNITED STATES
See your local distributor or write to: Dremel,
4915 Twenty-First Street,
Racine, WI 53406

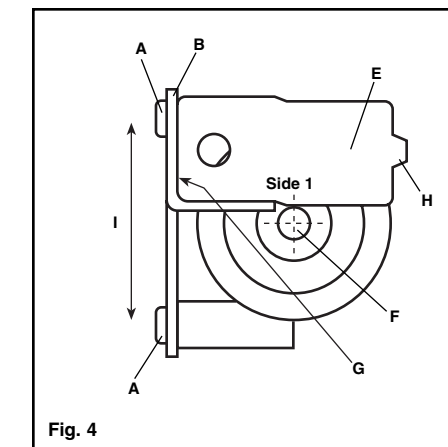
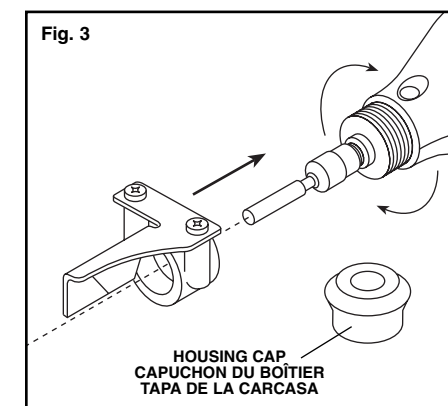
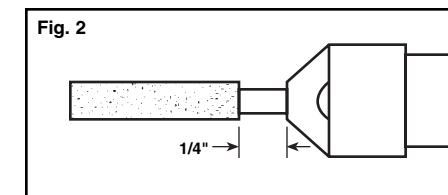
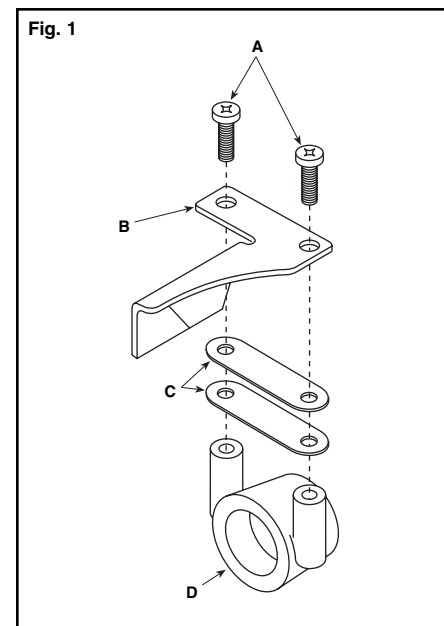

Fig. 4

VIEW: looking down at the tip of the tool with guide mounting screws to the left.

VUE vers la pointe de l'outil avec les vis de montage du guide à gauche

VISTA: Mirando hacia abajo, hacia la punta de la herramienta, con los tornillos de montaje de la guía ubicados a la izquierda.

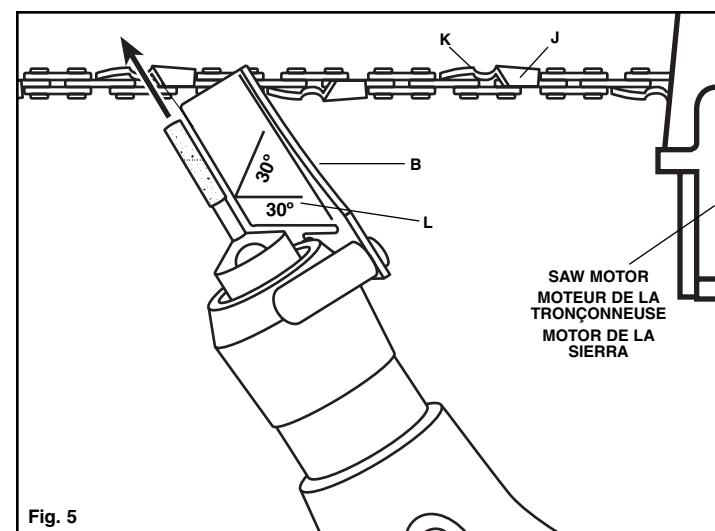

Fig. 5

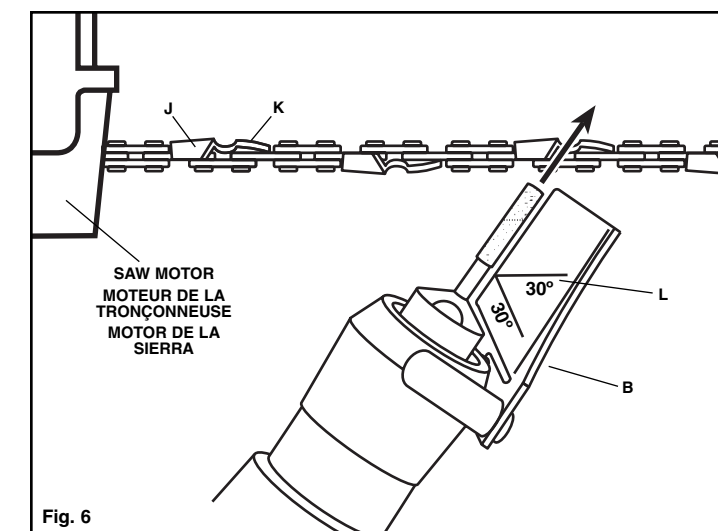

Fig. 6

⚠ WARNING Disconnect electrical plug or spark plug lead from the power source. Accidental start up could cause serious personal injury.

⚠ AVERTISSEMENT Débranchez la prise ou le fil de bougie. Tout démarrage intempestif risque de causer des blessures corporelles graves.

⚠ ADVERTENCIA Desconecte de la fuente de alimentación el enchufe eléctrico o el hilo de conexión de la bujía. Un arranque accidental podría causar lesiones personales graves.

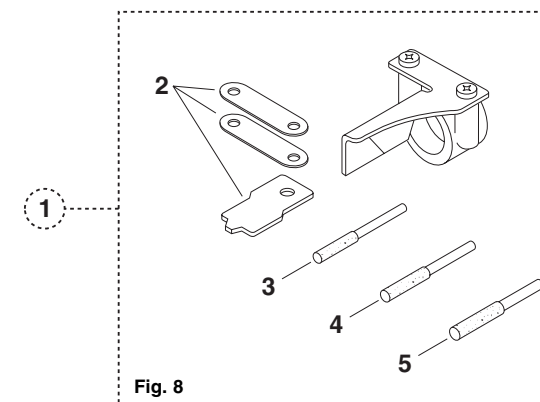
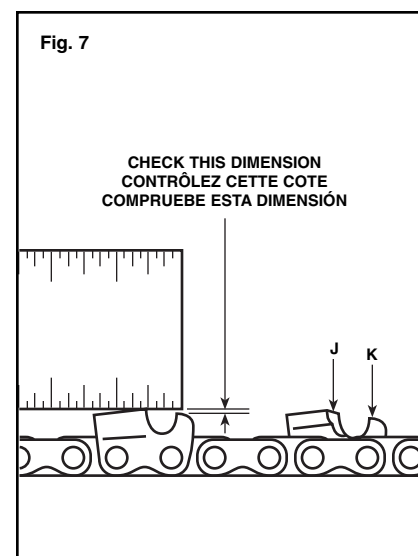

Fig. 8