

DESATM

HEATING PRODUCTS

SERVICE MANUAL LOW PRESSURE PROPANE/LP GAS HEATERS

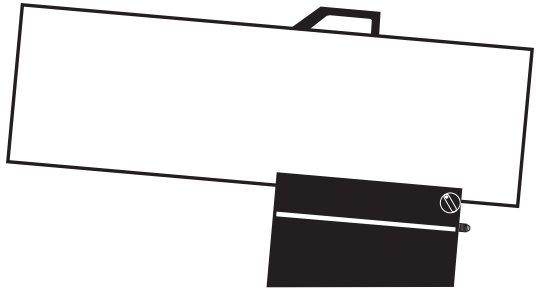
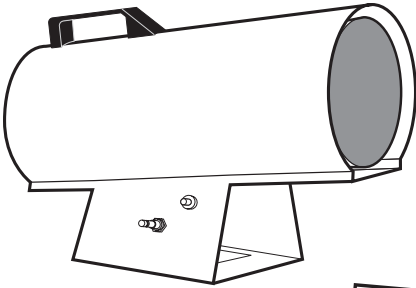
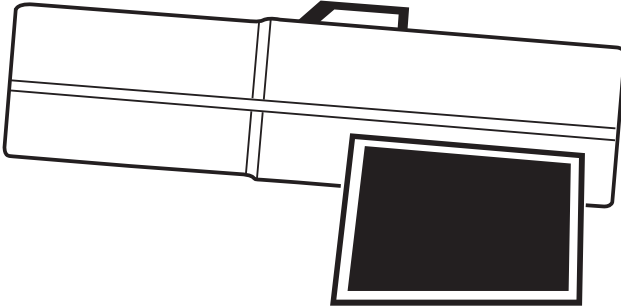

Save this manual for future reference.
For more information, visit www.desatech.com

TABLE OF CONTENTS

General Information	
Arrangement of Manual.....	5
Technical Service Department	5
Service Preparation.....	5
Tools Required	5
Specifications	
General Specifications	6
Heater Performance Specifications.....	7
Heater Performance Specifications.....	8
Component Operation	
All Systems Working Together	9
Installation	14
Operation and Troubleshooting	
Sequence of Operation - Flow Chart	15
Test and Repair Procedures	18
Wiring Diagrams.....	22
Accessories and Service Information	
Accessories	28
Technical Service	28
Illustrated Parts List.....	28
Replacement Parts.....	28

SAFETY INFORMATION

This service manual is intended for use by individuals with adequate electrical and mechanical skills. Attempts to repair this heater by individuals without those skills can result in personal injury as well as property damage.

IMPORTANT: Read this owner's manual carefully and completely before trying to assemble, operate or service this heater. Improper use of this heater can cause serious injury or death from burns, fire, explosion, electrical shock and carbon monoxide poisoning.

⚠ DANGER: Carbon monoxide poisoning may lead to death!

⚠ WARNING: This product contains and/or generates chemicals known to the State of California to cause cancer or birth defects or other reproductive harm.

Carbon Monoxide Poisoning: Early signs of carbon monoxide poisoning resemble the flu, with headaches, dizziness and/or nausea. If you have these signs, the heater may not be working properly. **Get fresh air at once!** Have heater serviced. Some people are more affected by carbon monoxide than others. These include pregnant women, persons with heart or lung disease or anemia, those under the influence of alcohol and those at high altitudes.

Propane Gas: Propane gas is odorless. An odor-making agent is added to propane gas. The odor helps you detect a propane gas leak. However, the odor added to propane gas can fade. Propane gas may be present even though no odor exists.

SAFETY INFORMATION

Continued

Make certain you read and understand all warnings. Keep this manual for reference. It is your guide to safe and proper operation of this heater.

1. For indoor use only. Provide adequate ventilation.
2. Use only in well vented areas. Provide at least a four and one half (4.5) square foot opening of fresh, outside air while running this heater. This is based on heater output of 3 ft³ per 100,000 Btu/hr.
3. Do not use heater outdoors or in occupied dwellings. Primarily intended for temporary heating of buildings under construction, alteration, or repair.
4. Do not use heater in living or sleeping quarters.
5. Do not bypass safety devices unless instructed to do so.
6. Never use heater where gasoline, paint thinner, or other highly flammable vapors are present.
7. Do not expose heater to water spray, rain, or dripping water.
8. Install and use heater with care. Follow all local ordinances and codes. In the absence of local ordinances and codes, refer to ANSI/NFPA 58-1989. This instructs on the safe storage and handling of propane gases.
9. Check heater for damage before each use. Do not use a damaged heater.
10. Use only propane gas set up for vapor withdrawal.
11. Keep propane tank(s) below 100° F.
12. Use only in places free of flammable vapors or high dust content.
13. Do not use heater below ground level. Propane gas is heavier than air. If a leak occurs, propane gas will sink to the lowest possible level.
14. Use only the electrical voltage and frequency specified on model plate.
15. Electrical Grounding Instruction – This appliance is equipped with a three-prong (grounded) plug for your protection against shock hazard and should be plugged directly into a properly grounded three-prong receptacle.
16. Use only a three-prong, grounded extension cord.
17. Make sure all electrical connections are secure and all leads are in place before connecting heater to electrical outlet.
18. Use only the hose and factory preset regulator provided with the heater.
19. Inspect hose before each use of heater. If highly worn or cut, replace before using heater. Use the replacement hose assembly that is specified by the manufacturer.
20. Keep heater at least six feet from propane tank(s). Do not point heater at propane tank(s) within 20 feet.
21. General minimum heater clearances from combustibles: Outlet: 8 Feet; Sides: 2 Feet; Top: 6 Feet; Rear: 2 Feet (Exact heater clearances are based on individual heater output.)
22. Locate heater on stable and level surface while it is hot or operating.
23. Keep children and animals away from heater.
24. Turn off propane supply and unplug heater when not in use.
25. When used with thermostat, heater may start anytime.
26. Never block air inlet (rear) or air outlet (front) of heater.
27. Never move, handle, or service a hot, operating, or plugged-in heater.
28. Never attach duct work to front or rear of heater.
29. Use only original replacement parts. This heater must use design-specific parts. Do not substitute or use generic parts. Improper replacement parts could cause serious or fatal injuries.

SAFETY INFORMATION

Continued

The following safety features are important and must be retained after servicing heater. Be sure you have not circumvented any of them and have replaced key components identical to ones supplied with heater.

Safety Feature	Description	Heater Models
Flame Loss Protection	If a heater fails to ignite and/or experiences loss of flame, the gas valve will close within a short time period. The heater must be manually reactivated.	All propane/LP and natural gas models
U.L. Listed Hoses and Regulators	U.L. listed assembly's meet rigorous standards for strength and integrity. Likewise U.L. listed regulators meet rigorous criteria for performance and integrity.	All models
Excess Flow Protection	A special excess flow POL is used for the cylinder connection fitting. It can close if there is a major unplanned propane leak downstream of the cylinder fitting (such as a broken regulator). This special POL fitting restricts flow (when closed) to substantially less than that of the appliance itself (except for small IR heaters).	All models
Agency Certified Gas Valves	CSA International or U.L. certifies Main burner gas valves to a rigorous gas valve standard.	All models
Over Temperature Protection	Forced air heaters are designed for a specific outlet air temperature. If the temperature exceeds the allowable tolerances due to blockage, excessive burn rate, etc., a high limit control will automatically shut off the gas valve.	All electrically operated heater models
Motor or Fan Failure Protection	If the motor or fan fails a high limit control will shut off the gas valve within a short period of time.	All forced air heaters
Air Proving Switch	If the motor or fan fails a Air Proving Switch will shut off the gas valve.	7000-FACV

GENERAL INFORMATION

ARRANGEMENT OF MANUAL

This manual will help the service technician understand and correct problems on the DESA Heating Products low pressure propane gas heater.

The first section of this manual contains basic information about the operation of certain heater components. Study this information closely. It will help you understand how the components function in the heater.

The last section of this manual contains service procedures. It provides a quick reference about heater problems that may occur. These procedures will help you diagnose the problem. Some illustrations in this manual may not depict the actual heater model. They are for reference only.

TECHNICAL SERVICE DEPARTMENT

The Technical Service Department, located in Bowling Green, Kentucky, is committed to assisting our Authorized Service Centers to increase their service knowledge, so that they can provide prompt, efficient service. This Service Manual covers the majority of problems that are associated with the heaters. However, as with any product, certain problems can arise which have not been covered. If such problems arise, please call the Technical Service Department at 1-866-672-6040 or visit our website at www.desatech.com.

SERVICE PREPARATION

A clean work area at the start of each job is essential for efficient service work. Heaters which are extremely dirty should be cleaned prior to service. Cleaning will occasionally uncover the problem area. Tools needed for the job should be obtained before work is started. Delays resulting from locating tools result in lost time and wages.

TOOLS REQUIRED

In addition to common hand tools, the service shop should have the following tools and instruments for proper repairing of the heaters. These instruments will be referred to throughout this manual.

- Volt Ohmmeter
- Flame Simulator*

***IMPORTANT:** The flame simulator is intended for use by service shops which do not have a propane gas supply available. If a propane gas supply is available, the flame simulator is not needed.

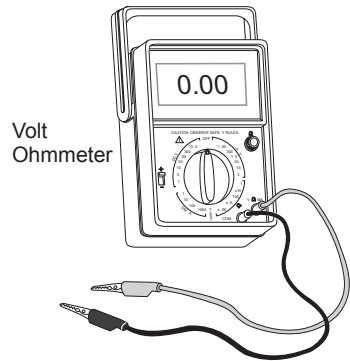

Volt
Ohmmeter

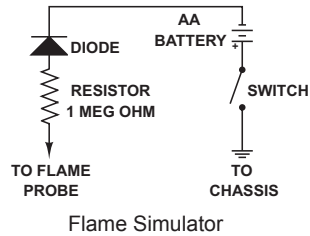

Flame Simulator

SPECIFICATIONS

GENERAL SPECIFICATIONS

Electrical

Connect heater to a standard electrical outlet (120V/60Hz). Plug power cord of heater into a three-prong, grounded extension cord. Extension cord must be at least six feet long. Extension cord must be U.L. listed. Use extension cord with proper wire size to assure 120 volt operation. See the following chart.

LENGTH OF CORD WIRE SIZE (AWG)

100 Ft.	No. 14
200 Ft.	No. 12
300 Ft.	No. 10
400 Ft.	No. 8
500 Ft.	No. 6

Propane Tank Sizing

Use this heater only with a Propane Vapor Withdrawal Supply System. See Chapter 5 of the *Standard for Storage and Handling of Liquefied Petroleum Gas, ANSI/NFPA 58*, current revision. Your local library or fire department will have this booklet.

The amount of propane gas ready for use from propane tanks varies. Two factors decide this amount:

1. The amount of propane gas in tank(s)
2. The temperature of tank(s)

The following chart shows the number of 100 pound tanks needed to run this heater. Do not operate this heater with any tank smaller than 100 pounds.

Temperature (°F) at Tank	Number of Tanks Needed	
	80/155 Btu	30-55 Btu
32°	2	1
20°	2	1
10°	3	1
0°	3	1
-10° or lower	Use Larger Tank	2

Less gas will be vaporized as the temperature goes down. Two or more 100 pound tanks or one larger tank may be needed in colder weather. Your local propane gas dealer can help you select the proper supply system.

Ventilation

Use this heater only in well ventilated areas. Provide a fresh, outside air opening of at least three (3) square feet per 100,000 Btu/hr. If possible, it is better to provide cross ventilation to achieve better air movement.

Heater Size Btu/hr Square Foot Opening

30/35/40,000	1.0 sq. ft.
50,000	1.6 sq. ft.
100,000	3.2 sq. ft.
150,000 (155)	4.5 sq. ft.

Heater Sizing

The user should be aware of the proper size heater needed for a particular application. It is easy to see that a 150,000 BTU/Hr heater would not heat a large warehouse, but the question is sometimes asked "What size heater should I use?" A simple formula that can be used to determine heater BTU requirements follows:

Cubic Feet of Area x .133 x Desired Temp. Rise °F = BTU Size Needed.

Example:

Area: 80' X 40' X 10' = 32,000 Cubic Feet
Desired Temperature Rise: 30°F

32,000 (Cu. Ft.) x .133 (Factor) = 4256

4256 x 30 (Temp. Rise) = 127,680 (Proper Heater Size)

SPECIFICATIONS

Continued

HEATER PERFORMANCE SPECIFICATIONS

Output Rating (BTU/Hr)	30,000	35,000	40,000
Fuel	———— Propane Vapor Only (ALL MODELS) ————		
Fuel Consumption			
Gallons (liters)/Hour	.33 (1.25)	.38 (1.44)	.44 (1.65)
Pounds(kg)/Hour	1.4 (0.63)	1.62 (1.74)	1.86 (0.84)
Supply Pressure To Regulator			
Minimum (for purposes of input adjustment)	20 psi	20 psi	20 psi
Maximum	———— Tank Pressure or 200 psi (ALL MODELS) ————		
Regulator Outlet Pressure	10 psi	10 psi	10 psi
Manifold Pressure	10.1 psi	9.7 psi	9.7 psi
Hot Air Output (CFM Approx)	175	175	175
Motor	3045 RPM, 1/40 HP	3045 RPM, 1/40 HP	3045 RPM, 1/40 HP
Electric Input	120V/60Hz	120V/60Hz	120V/60Hz
Amperage	.6	.6	.6
Ignition	Manual, Piezo	Manual, Piezo	Manual, Piezo
Temperature Range for Heater Operation	-20° F to 85° F* (-29° C to 29.4°C)*	-20° F to 85° F* (-29° C to 29.4°C)*	-20° F to 85° F* (-29° C to 29.4°C)*

* When running heater in temperatures above 85° F (29.44° C), high internal temperatures may cause thermal limit device to shut down heater.

Output Rating (BTU/Hr)	65,000	85,000	100,000	150,000
Fuel	———— Propane Vapor Only (ALL MODELS) ————			
Fuel Consumption				
Gallons (liters)/Hour	0.7 (2.65)	.93 (3.52)	1.1 (4.16)	1.6 (6.06)
Pounds(kg)/Hour	3.0 (1.36)	3.9 (1.77)	4.6 (2.09)	7.1 (3.22)
Supply Pressure To Regulator				
Minimum (for purposes of input adjustment)	———— 10 psi (65.96 Kpa) (ALL MODELS) ————			
Maximum	———— Tank Pressure or 200 psi (ALL MODELS) ————			
Regulator Outlet Pressure	Factory Preset	Factory Preset	Factory Preset	12.5" WC
Manifold Pressure	10" (4 cm) WC	10" (4 cm) WC	10" (4 cm) WC	9.8" WC
Hot Air Output (CFM Approx)	475	475	475	550
Motor	3200 RPM 1/10 HP	3200 RPM 1/10 HP	3200 RPM 1/10 HP	3430 RPM 1/8 HP
Electric Input	———— 120V/60Hz (ALL MODELS) ————			
Amperage	2.9	2.9	2.9	2.2
Ignition	Continuous	Continuous	Continuous	Direct Spark Interrupted Type
Ignitor Gap	———— .13"/.15" (3.3/3.8 mm) (ALL MODELS) ————			

SPECIFICATIONS

Continued

HEATER PERFORMANCE SPECIFICATIONS

	30-FAS SPC-30	40-FAC SPC-40	45-FAC SPC-45	55-F SPC-55
Output Rating (BTU/Hr)	30,000	40,000	25,000-45,000	30-55,000
Fuel	Propane Only	Propane Only	Propane Only	Propane Only
Fuel Consumption Pounds (kg)/Hour	1.4 (0.64)	1.8 (0.82)	1.2 - 2.1 (0.54 - 0.95)	1.4 - 2.5 (0.64 - 1.1)
Supply Pressure To Regulator Minimum*	5 psi (34.5 kPa)	5 psi (34.5 kPa)	5 psi (34.5 kPa)	5 psi (34.5 kPa)
Maximum	Tank Pressure	Tank Pressure	Tank Pressure	Tank Pressure
Regulator Outlet Pressure	11" WC	11" WC	11" WC	11" WC
Hot Air Output (CFM Approx)	140	250	250	300
Electric Input	115V, 60Hz 1ø, 3a	115V, 60Hz 1ø, 3a	115V, 60Hz 1ø, 3a	115V, 60Hz 1ø, 3a
Ignition	Direct Spark	Direct Spark	Direct Spark	Direct Spark
High Temperature Control	240° F (116° C)	240° F (116° C)	240° F (116° C)	240° F (116° C)
Min. Ambient Temp. Rating	0° F (-17.8°C)	0° F (-17.8°C)	0° F (-17.8°C)	0° F (-17.8°C)

* For purposes of input adjustment

	85-FAC SPC-85	125-F SPC-125	150-F	170-F SPC-170
Output Rating (BTU/Hr)	50,000-85,000	75,000-125,000	150,000	125,000-175,000
Fuel	Propane Only	Propane Only	Propane Only	Propane Only
Fuel Consumption Pounds(kg)/Hour	2.3-3.9 (1.0-1.3)	3.5-5.8 (1.58-2.63)	7 (3.2)	5.8-7.9 (2.6-3.6)
Supply Pressure To Regulator Minimum*	5 psi (34.5 kPa)	5 psi (34.5 kPa)	5 psi (34.5 kPa)	5 psi (34.5 kPa)
Maximum	Tank Pressure	Tank Pressure	Tank Pressure	Tank Pressure
Regulator Outlet Pressure	28" WC	28" WC	11" WC	28" WC
Hot Air Output (CFM Approx)	350 (144.8 cm)	350 (144.8 cm)	350 (144.8 cm)	450 (1397 cm)
Electric Input	150V, 60Hz 1ø, 3a	150V, 60Hz 1ø, 3a	150V, 60Hz 1ø, 3a	150V, 60Hz 1ø, 3a
Ignition	Direct Spark	Direct Spark	Direct Spark Interrupted Type	Direct Spark Interrupted Type
High Temperature Control	240° F (116° C)	240° F (116° C)	240° F (116° C)	240° F (116° C)
Min. Ambient Temp. Rating	0° F (-17.8°C)	0° F (-17.8°C)	0° F (-17.8°C)	0° F (-17.8°C)

* For purposes of input adjustment

COMPONENT OPERATION

ALL SYSTEMS WORKING TOGETHER

There are three basic systems within the heater: the fuel system, the air system, and the safety control system.

FUEL SYSTEM

The hose/regulator assembly attaches to the propane gas supply.

Note: It is extremely important that the pressure regulator be used with the heater at all times.

The pressure regulator maintains the heater gas supply at a constant pressure. Inside the inlet fitting of the pressure regulator is the excess flow check valve. The excess flow check valve stops the gas flow if the hose becomes cut or ruptured. The propane gas moves through the solenoid valve and out the nozzle.

AIR SYSTEM

When power is supplied to the heater, the motor turns the fan. The fan pushes air into and around the combustion chamber. The air pushed into the combustion chamber mixes with the fuel from the nozzle. The remaining air is pushed around the combustion chamber. The air is heated by the combustion chamber and provides a stream of clean, hot air.

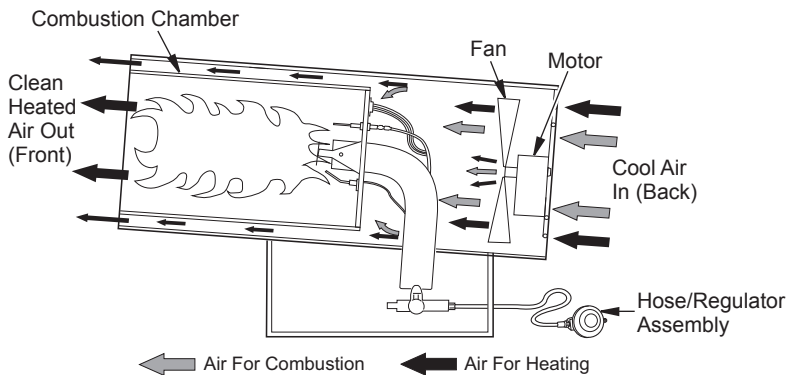

30,000 Btu/hr Model

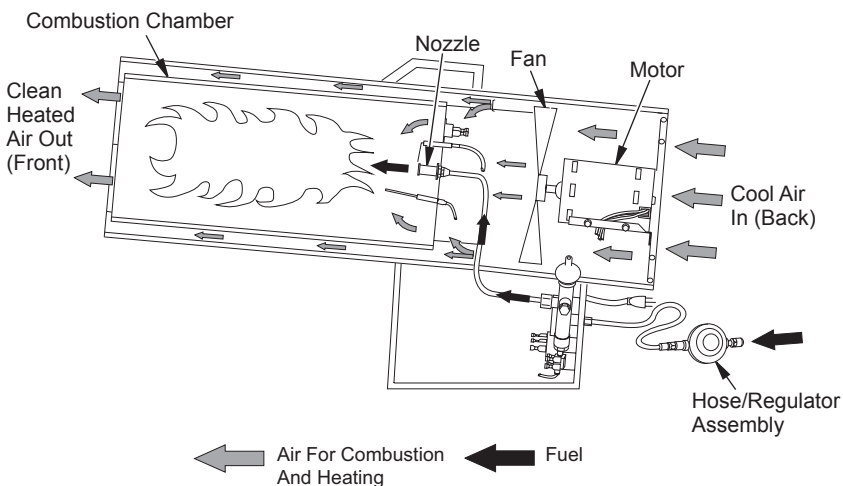

100,000 Btu/hr Model

COMPONENT OPERATION

Continued

SAFETY CONTROL SYSTEM (155 Models only)

This system consists of two basic circuits: the ignitor circuit and the control circuit.

Ignitor Circuit The safety control delivers very high voltage to the ignitor/sensor. This causes an arc to jump between the electrode and the nozzle. This arc ignites the fuel/air mixture.

Control Circuit After ignition, the safety control monitors the combustion flame. The safety control sends an electrical current from the ignitor/sensor into the flame. This current then returns to the heater chassis. If the flame is lost, the safety control attempts to reignite the heater. If heater reignites, the safety control returns to monitoring the flame. If heater does not reignite, the safety control shuts off power to the solenoid valve. This will stop gas flow into the heater.

The thermal switch shuts off power to the solenoid valve if internal temperatures of heater are too high. Restricted air flow at heater inlet or outlet and fan not turning can cause high internal temperatures.

The excess flow check valve stops the gas flow if the hose becomes cut or ruptured.

⚠ WARNING: Never connect the heater directly to a propane tank, even for a short period of time. Always use the regulator provided with the heater.

Gas Supply

A propane gas tank supplies the fuel to the heater. The propane vapor leaves the tank due to the gas pressure within the tank. This pressure varies depending on the temperature of the propane gas. When the temperature is high, the liquid expands and the pressure increases. When the temperature is low, the liquid contracts and the pressure decreases.

Since less gas will be vaporized in cold weather, a larger supply system may be required for proper vaporization (see *Propane Tank Sizing*, page 6). If necessary, forced vaporization may be used. Contact your local propane gas supplier for assistance.

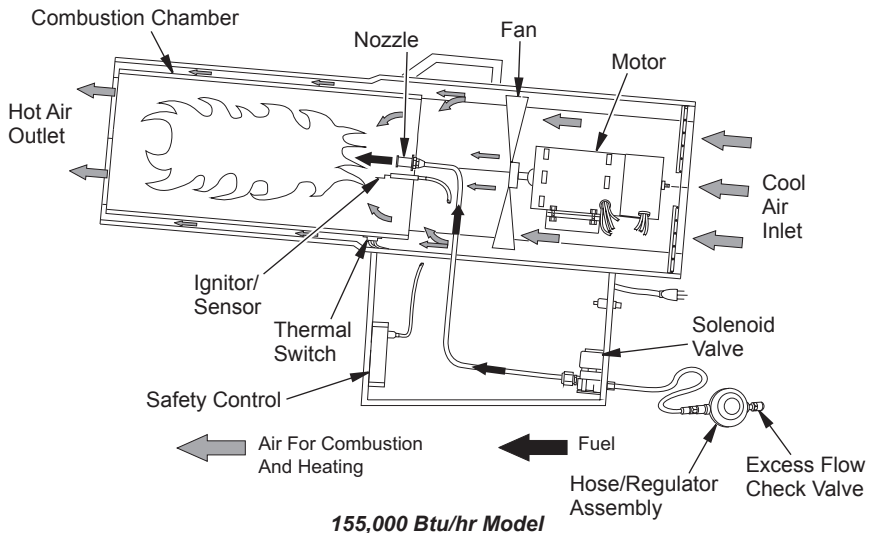

COMPONENT OPERATION

Continued

Pressure Regulator

For proper operation, the heater must operate at a constant supply pressure. To maintain this pressure, a pressure regulator is connected to the propane tank. The regulator reduces the pressure from the propane tank to the operating pressure of the unit. The regulator is preset at the factory. The regulator is not serviceable. Do not disassemble.

IMPORTANT: Install regulator to propane tank with regulator vent pointing down. Pointing vent down protects regulator from weather damage. This pressure regulator is part of the inlet hose. It must be used even if propane tank has a pressure regulator.

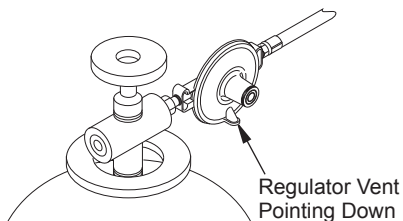

Solenoid Valve (155,000 Models Only)

The solenoid valve is an automatic valve for the propane gas supply. The solenoid valve operation depends on the safety control. Power is supplied to the solenoid valve from the safety control. The valve opens and allows gas to flow to the nozzle. When power to the solenoid valve is stopped, the valve closes. The flow of gas to the nozzle is stopped.

Note: Remove the plug to monitor heater manifold pressure. Install a properly-sized hose barb or nipple in place of plug. Measure manifold pressure using a 0" – 16" (or larger) water column manometer. Connect manometer to the hose barb or nipple. Check for gas leaks at hose end connections before testing.

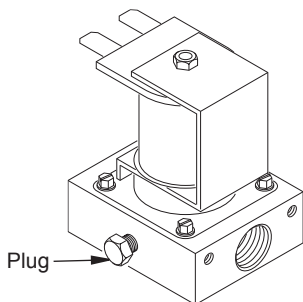

Thermal Switch

The thermal switch responds to overheating conditions. The switch shuts off power to the solenoid valve or control valve when high internal temperatures occur. After servicing heater, be sure to gently pull all excess lead wire down into the heater base.

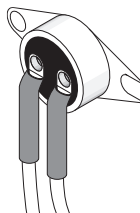

Safety Control

The safety control system consists of the following electrical circuits:

- A) Electronic flame sensing network
- B) Direct spark ignition source
- C) Supply source for solenoid valve

The safety control system uses a single probe to ignite and monitor the burner flame. Upon call for heat, the safety control initiates a brief purge cycle and starts the ignition cycle.

The purge cycle allows the motor to reach full speed. This provides adequate air flow through the heater.

The ignition cycle consists of high voltage sparking from the ignitor/sensor and the opening of the solenoid valve.

If the heater does not ignite (flame is not present), the safety control will shut off power to the solenoid valve. This condition is called "lockout." This will stop gas flow to the nozzle. The motor will continue to run. To reset the system, you must turn off heater for at least 10 seconds. A guide to troubleshooting the safety control is in the *Operation and Troubleshooting* section on page 15.

Note: Two different safety controls are used on the 155 model heaters. The wire leads have the same color and function on each, however, wire locations may be different.

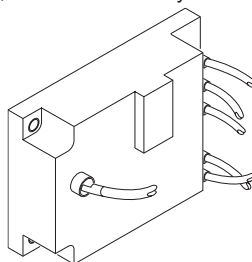

COMPONENT OPERATION

Continued

Ignitor/Sensor (155 models only)

The ignitor/sensor ignites the fuel air mixture in the combustion chamber. It also monitors the flame after ignition. If ignition fails or the flame goes out during operation, the ignitor/sensor "tells" the safety control to shut off power to the solenoid valve. This will stop gas flow to the nozzle. On 155 models only, the ignitor also monitors the flame circuit.

The typical air gap between the nozzle and the ignitor/sensor is .13 to .15 inch.

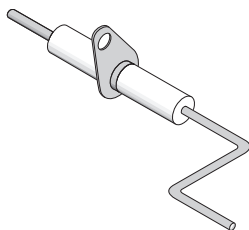

Fan Location

The fan is located on the end of the motor shaft. The fan pushes air into and around the combustion chamber. The air pushed into the combustion chamber is used for combustion. The air pushed around the combustion chamber is heated and exits through the outlet of heater.

When removing the fan from the motor shaft, be careful not to damage the fan pitch. This could alter the performance of the heater. Do not intentionally alter the fan pitch. This heater is designed to work with the preset fan pitch.

When replacing fan on motor shaft, make sure setscrew is touching the back of the flat surface on motor shaft (see illustration below). Tighten setscrew firmly (40-50 inch-pounds).

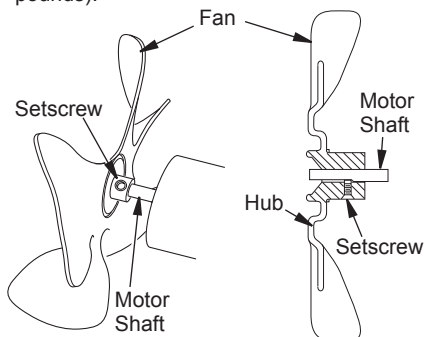

Motor Start Relay (155,000 Models Only)

This heater has a split-phase motor. All split-phase motors made after 1998 have a start capacitor on them. Split-phase motors have both an auxiliary and main winding. The auxiliary winding is used when starting heater. The main winding then takes over to run motor. Both the auxiliary and main windings energize during start-up. The motor start relay shuts off power to the auxiliary winding after motor reaches 80% of rated speed.

The relay contacts are in series with the auxiliary winding. When the motor starts, the high main winding current creates a magnetic field in the relay coil that closes the relay contacts. This energizes the auxiliary winding. As the motor speed increases, the current through the relay decreases. This allows gravity to open the contacts and shut off the auxiliary winding.

Nozzle

The nozzle directs the fuel into the combustion chamber. The fuel then mixes with combustion air and is ignited. The nozzle has drilled orifices that control the fuel flow into the combustion chamber.

Combustion Chamber

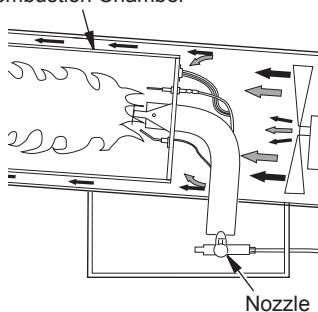

30,000 Btu/hr Model

Combustion Chamber

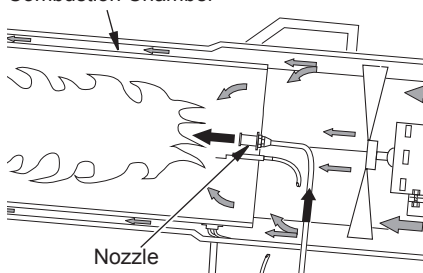

155,000 Btu/hr Model

COMPONENT OPERATION

Continued

Motor

155 Models The motor is a split-phase motor with over-temperature and over-current protection. The motor is 1/8 horsepower designed to run at 3430 RPM.

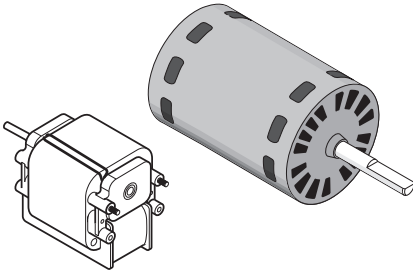

LP 100 and smaller models LP 100 and smaller units have a single phase motor. LP 100 motor is a 1/10 horsepower designed to run at 3200 RPM. LP 30 to 50's motor is a 1/40 horsepower designed to run at 3045 RPM.

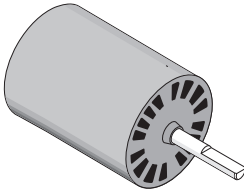

Relay

A relay is a safety device designed to shut off gas flow through gas valve if there is any interruption of electrical current. Relay is an open circuit (terminals 4 and 6) until electrical power is supplied (terminals 7 and 8).

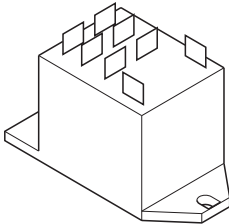

Thermocouple

The thermocouple is 2 dissimilar types of metal that when heated create a low electrical current to energize the Electromagnetic Power Unit of the gas valve.

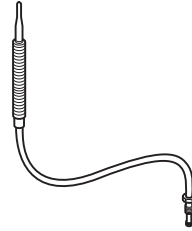

Control Valve

The control valve is a manually operated component. The control knob has to be pressed and held to allow gas flow through to burner. Once the flame heats thermocouple, current is produced to allow valve to remain open.

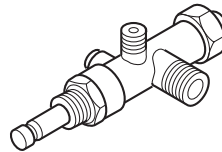

INSTALLATION

⚠ WARNING: Test all gas piping and connections for leaks after installation or servicing. Correct all leaks at once.

IMPORTANT: Review and understand the warnings in the Safety Information Section. They are needed to safely operate this heater. Follow all local codes when using this heater.

1. Provide propane supply system (see *Propane Supply* in owner's manual).
2. Connect POL fitting on hose/regulator assembly to propane tank(s). Turn POL fitting counterclockwise into threads on tank. Tighten firmly using 7/8" wrench. **IMPORTANT:** Tighten regulator with vent pointing down. Pointing vent down protects regulator from weather damage.

3. Connect hose to inlet connector. Tighten firmly using a wrench.

IMPORTANT: Extra hose or piping may be used if needed. Install extra hose or piping between hose/regulator assembly and propane tank. The regulator supplied with heater must be used even if propane tank has one.

4. Open propane supply valve on propane tank(s) slowly. **Note:** If not opened slowly, excess-flow check valve on propane tank will stop gas flow. If this happens, close propane supply valve and open again slowly.
5. Check all connections for leaks. Apply mixture of liquid soap and water to gas joints. Bubbles forming show a leak that must be corrected.

⚠ WARNING: Never use an open flame to check for a leak. Apply a mixture of liquid soap and water to all joints. Bubbles forming show a leak that must be corrected. Correct all leaks at once.

6. Close propane supply valve.

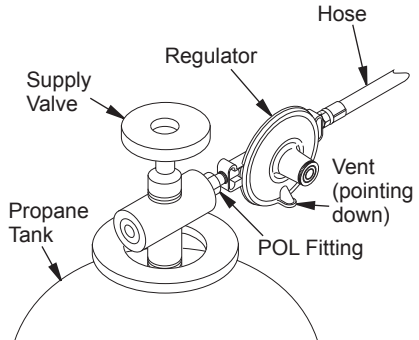

Regulator With Vent Pointing Down

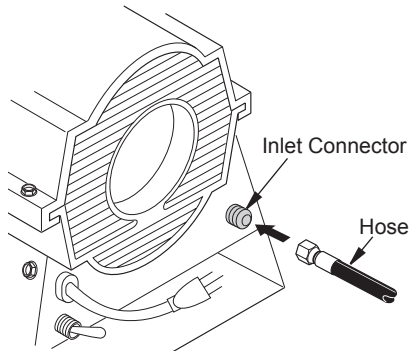

Hose and Inlet Connector

OPERATION AND TROUBLESHOOTING

SEQUENCE OF OPERATION - FLOW CHART

Normal Operation

1. Manual Start/Restart:
Switch turned to "ON" position by the operator, or thermostat turns heater on automatically.

2. Pre-Purge:
Motor starts, solenoid valve closed, and ignitor off for 2 to 5 seconds.

3. Ignition Trial:
Solenoid valve opens, ignitor energizes for 4 to 12 seconds.

4. Flame Recognition:
Ignition occurs and safety control detects flame.

Test and Repair Procedure Number(s)
(See *Test and Repair Procedures*, page 18)

Symptoms and Possible Problems

Motor does not start, or does start but runs slowly	
Damaged thermostat (if used)	18
Damaged extension cord	18
No power at electrical outlet	18
Incorrect voltage to heater	18
Extension cord not connected to electrical outlet	—
Loose or broken wire/connection	18
Damaged ON/OFF switch	18
Damaged motor	13
Damaged motor start relay	12
Incorrect fan pitch, loose fan, or damaged fan	18
Mechanical obstruction blocking fan rotation	18

No fuel flow

Fuel supply valve not turned on	—
Gas hose kinked or damaged	14
Excess-flow check valve actuated	14
Low fuel supply in tank	6
Low tank pressure due to very cold temperatures	6
Regulator blocked or damaged	11
Fuel line or nozzle blocked	12
Damaged solenoid valve	19
Loose or broken wire/connection	18
Blown safety control fuse (if equipped)	19
Damaged safety control	19
Damaged thermal switch	19

Ignitor does not spark

Loose or broken wire/connection	18
Blown safety control fuse (if equipped)	19
Damaged safety control	19
Incorrect ignitor/sensor air gap to nozzle	20
Ignitor electrode damaged	20

— NO —

Lock Out

This occurs at end of ignition trial period. Solenoid valve is closed, ignitor is off. Heater requires manual restart.

continued on next page

OPERATION AND TROUBLESHOOTING

Continued

Normal Operation	Symptoms and Possible Problems	Test and Repair Procedure Number(s) <i>(See Test and Repair Procedures, page 18)</i>
<p>5. Normal Operation: Burner operates, solenoid valve held open, and ignitor off.</p>	<p>Flame goes out after short period of time</p> <p>Low fuel supply in tank 10</p> <p>Low tank pressure due to very cold temperatures 6</p> <p>Improperly sized propane tank 6</p> <p>Air inlet blocked 20</p> <p>Hot-air outlet blocked 20</p> <p>Surrounding Air temperatures too high (thermal switch) ... 11, 19</p> <p>Excessive debris in surrounding air 20</p> <p>Damaged or loose ground wire to chassis 20</p> <p>Damaged or loose high-voltage cable 20</p> <p>Blockage or damage to gas delivery system 11, 12, 14</p> <p>Damaged safety control or ignitor/sensor 11, 12</p> <p>Damaged thermal switch 11, 19</p> <p>Heater cycles intermittently</p> <p>Strong wind blowing into hot-air outlet 20</p> <p>Thermostat (if used) not located properly 18</p> <p>Damaged thermostat (if used) 18</p> <p>Loose or broken wire/connection 18</p> <p>Damaged thermal switch 19</p> <p>Excessive flames extending out front of heater</p> <p>Propane supply type incorrect 27</p> <p>Air inlet blocked 20</p> <p>Excessive debris in surrounding air 20</p> <p>Strong wind blowing into hot-air outlet 20</p> <p>Incorrect voltage to heater 18</p> <p>Incorrect fan pitch or damaged fan 18</p> <p>Damaged regulator 11</p> <p>Damaged motor 18</p> <p>Damaged thermal switch 19</p>	
<p>6. Flame Outage: Safety control detects no flame, attempts re-ignition, lock out occurs if re-ignition is unsuccessful.</p>		

OPERATION AND TROUBLESHOOTING

Continued

**Test and Repair
Procedure Number(s)**
*(See Test and Repair
Procedures, page 18)*

Normal Operation

**Symptoms and
Possible Problems**

1. Switch turned to "on" by operator (if so equipped) or plug unit into a 110 power supply. Press control valve, press piezo to ignite fuel.	
2. Sparks with no fuel odorant.	Fuel supply not turned on 10 Low fuel supply in tank 10
3. No spark with fuel flow.	Ignitor cable disconnected 20 Ignitor cracked 20 Ignitor gap too wide 20
4. Ignites burns as long as control valve is pressed.	Releasing control knob prematurely 13 Faulty thermocouple 21 Faulty relay (if equipped) 21 Excessive room temperature 19
5. Burns for a short period, flame goes out, motor still running.	Excessive room temperature 19 Fuel supply not great enough 10
6. Fan stops turning.	Electrical supply disconnected 18

TEST AND REPAIR PROCEDURES

⚠ WARNING: Never service heater while it is plugged in, connected to propane supply, operating, or hot. Severe burns and electrical shock can occur.

1. Thermostat Damaged

Disconnect thermostat and try to operate heater without it. If heater operates normally, thermostat is defective.

2. Extension Cord (damaged)

Visually inspect extension cord. If cord is broken or damaged, replace.

3. Electrical Outlet

There may be no power at the electrical outlet. Check the fuse box or circuit breaker box to see if fuse is blown or circuit breaker is tripped.

4. Incorrect Voltage

You must plug heater into a 120V/60Hz electrical outlet. You must use a properly-sized extension cord (see *Electrical*, page 6).

5. Wire/Connection

Physically inspect wires and electrical connections at the terminal block and safety control for damage or proper fit.

6. ON/OFF Switch

With the heater unplugged, remove the side access cover from the heater base. Remove the black wires from the ON/OFF switch. Set ohmmeter to "RX1" scale. Check continuity (zero ohms) of the switch by attaching ohmmeter leads to switch terminals. Low resistance (zero ohms) should be observed when the switch is in the ON position. An open circuit (extremely high ohms reading) should be observed when switch is in the OFF position. Replace the ON/OFF switch if defective.

7. Motor

Check resistance of motor windings. Disconnect white, red, and black wires from motor. Set ohmmeter to "RX1" scale. Measure resistance between white and red wires. Also measure resistance between white and black wires. Each test should be approximately 8.5 ohms.

Note: Motor resistance varies with temperature. The approximate motor resistance is 8.5 ohms (± 1.275 ohms) at 72° F.

8. Motor Start Relay

⚠ WARNING: Do not touch electrical connections or allow them to touch metal parts of heater. Electrical shock may occur.

Prepare a jumper wire approximately 8" long with a male quick disconnect terminal at one end and a test probe at the other end. Disconnect the black motor wire from the "S" terminal of relay. Connect this black wire to the male connection of jumper wire. Plug the heater into an electrical outlet. As the motor starts, touch the test probe to the "M" terminal of the relay until motor reaches full R.P.M. When motor reaches full R.P.M., remove test probe from "M" terminal. If the motor continues to run after the removing test probe, the motor start relay is faulty. Replace faulty motor start relay.

Note: Motor start relay is position sensitive. The heater must be level for relay to work properly.

9. Fan

Visually check fan for damaged or dirty blades. Clean fan or replace if needed. Check position of the fan on the motor shaft. Make sure the setscrew is touching the back of the flat surface on motor shaft. Tighten setscrew firmly (40-50 inch-pounds). Do not adjust fan blade pitch. If fan pitch is incorrect, replace fan.

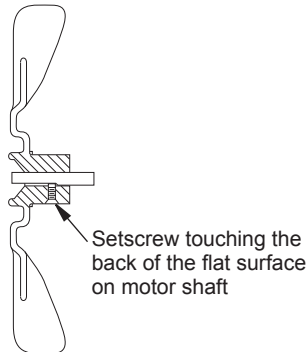

10. Mechanical Obstruction

Visually check to make sure the fan is free to turn and the shell is not interfering with fan rotation.

TEST AND REPAIR PROCEDURES

Continued

11. Pressure Regulator/Supply Line

Check pressure regulator and supply line for any blockage. Replace pressure regulator or supply line if you find blockage.

You can test regulator pressure by monitoring manifold pressure during heater operation (see *Solenoid Valve*, page 11).

12. Excess Flow Check Valve

Internal to the fuel gas connector is an excess flow check valve. If the supply tank valve is opened too rapidly, the sudden increase in pressure will cause the excess flow check valve to lockout and prevent gas flow through the regulator. To prevent this lockout condition, open supply tank valve slowly.

13. Low Propane Supply

Check propane supply tank(s). If supply is low, contact your nearest propane gas dealer.

14. Low Propane Gas Supply Pressure

The pressure regulator requires at least 10 psi pressure from the propane tank. The regulator then reduces the pressure to the correct manifold pressure. Low gas supply pressure can result from the following:

- Improperly sized propane tank or improperly sized line. If additional pressure regulators or piping are utilized, have installation checked by a qualified propane gas service person.
- Low outside temperatures. The lower the outside temperature, the lower the tank pressure.

See *Propane Tank Sizing*, page 6.

15. Nozzle and Fuel Line

Visually examine the nozzle and fuel line for foreign material or other damage. If you find blockage or damage, repair or replace as needed.

⚠ CAUTION: Do not attempt to increase the nozzle orifice size.

If you replace the nozzle, make certain the nozzle and solenoid valve fittings are tight. This will ensure against possible gas leak.

16. Solenoid Valve

- A. Turn off gas supply to heater. Remove access panel from side of base. Disconnect the orange cable from safety control and connect flame simulator in its place. Connect flame simulator ground wire to heater chassis. Plug heater into a standard outlet and turn ON/OFF switch to the ON position. Set voltmeter on the 250 vac scale. Check voltage to solenoid valve by connecting the meter across the solenoid valve terminals. The measured voltage should be line voltage. If measured voltage is incorrect, the safety control must be checked (see procedure 17).
- B. Turn off gas supply to heater. If measured voltage is correct, connect a suction bulb (aspirator) to inlet of solenoid valve and squeeze the bulb. If air does not pass through valve while voltage is present, the solenoid valve is defective. Replace defective solenoid valve.

17. Safety Control

- A. If no voltage is present at the solenoid valve and the thermal switch is operating, check all wiring connections and check the 2A fast-blow fuse (if equipped) in the safety control line between the safety control and the terminal block. Use the ohmmeter's "RX1" scale and check the resistance across the fuse. If the resistance is high, replace fuse. If the fuse has low resistance, check thermal switch. If thermal switch is good, replace safety control.
- B. If no spark is present during ignition trial, check ignitor/sensor and orange cable for damage. If they are good, check fuse (if equipped). Use the ohmmeter's "RX1" scale and check the resistance across the fuse. If the resistance is high, replace fuse. If fuse is good replace safety control.

18. Thermal Switch

The thermal switch, located on the combustion chamber (see *All Systems Working Together*, page 9), may have opened due to excessive heat being present in the chamber. This will cause heater to shut down. To check switch, set the ohmmeter on the "RX1" scale. With heater cool, check for continuity across the thermal switch by attaching the ohmmeter to the blue wires on switch.

The thermal switch may shut down heater if surrounding air temperature is above 85° F. Run heater in cooler temperatures.

TEST AND REPAIR PROCEDURES

Continued

19. Ignitor/Sensor

The ignitor/sensor provides the ignition source for the main burner and monitors the flame after ignition. Arcing around the ceramic material of the ignitor/sensor indicates an excessive air gap between the ignitor electrode and the burner nozzle or a damaged ignitor/sensor. If the ignitor/sensor requires an air gap adjustment, bend the center of electrode until a .13 to .15 inch gap is between the electrode and burner nozzle.

If the ceramic insulator is broken or the electrode is damaged, replace ignitor/sensor. To replace ignitor/sensor, remove top shell and remove the ignitor/sensor mounting screw and pull ignitor/sensor through the mounting hole. Unplug the ignitor/sensor from the cable.

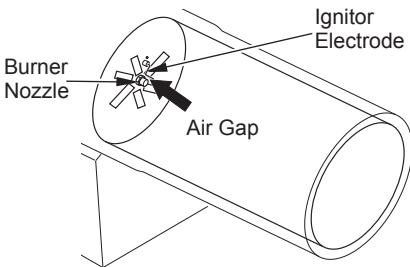

Air Gap Clearance Between Ignitor Electrode and Burner Nozzle

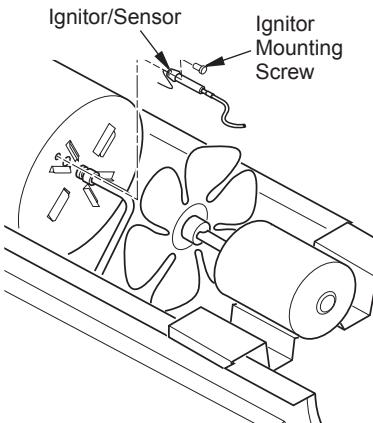

Removing Ignitor/Sensor

20. Air Inlet Blocked

Visually inspect fan guard at rear of heater for possible blockage. Remove blockage if found.

21. Hot-Air Outlet Blocked

Inspect the hot-air outlet for possible blockage. Remove blockage if found.

⚠ WARNING: Flammable materials blocking the hot-air outlet is a safety hazard! A fire or explosion may occur. Follow all heater clearances specified in the Safety Information section of this manual.

22. Debris in Surrounding Air

The heater flame burns with yellow and orange streaks when dust and debris is in the air stream going through the unit. Excessive foreign material in the air may also cause the heater to overheat. This will activate the thermal switch and cause a nuisance shutdown. Clean heater by removing accumulated dirt and dust. Do not operate heater in extremely dusty areas.

23. Ground Wire

The return path for the ignitor/sensor to the safety control is through the ground wire. Check ground wire connected to chassis. If loose, tighten firmly. If damaged, replace.

24. High-Voltage Cable

Check orange high-voltage cable between ignitor/sensor and safety control. If cable connections are loose, plug back in. If cable is damaged, replace.

25. Wind Blowing Into Hot-Air Outlet

Locate heater away from strong drafts. Do not let strong draft blow directly into heater outlet.

26. Thermostat Location

Do not place thermostat in vicinity of hot air flow from heater. Place thermostat to the sides or rear of heater.

27. Propane Supply Type

The propane supply type must be for vapor withdrawal. Do not use propane supply type for liquid withdrawal.

TEST AND REPAIR PROCEDURES

Continued

28. Control Valve

Turn off gas supply to heater. Remove bottom of base (if equipped). Remove thermocouple from valve. Using a digital multi-meter in the lowest ohm's setting, place the red lead to the internal center of valve (where thermocouple was removed) and black lead to casing of valve for ground. Resistance should be between 100 to 200 milliohms. Higher resistance indicates a short in the Electromagnetic Power Unit. Lower resistance indicates a broken wire in the Electromagnetic Power Unit.

29. Thermocouple

Turn off gas supply. Remove thermocouple from gas valve. Using a digital multi-meter set to the lowest DC millivolt setting (meter needs to have alligator clips on ends of leads), clip black lead to the very tip of thermocouple (end removed from valve). Clip red lead to the outer casing of thermocouple for ground. Relight unit output should be between 18 and 28 millivolts.

30. Relay

Turn off gas supply. Remove bottom of base (if equipped). Relay is a normally open circuit between terminals 4 and 6 which closes when current is supplied. Using a digital multi-meter measure the resistance. With no power to unit, resistance between terminals 4 and 6 is open circuit or no resistance. Apply power to relay. Resistance between terminals 4 and 6 should be less than 100 mili ohms.

WIRING DIAGRAMS

Electrical Ladder Diagram

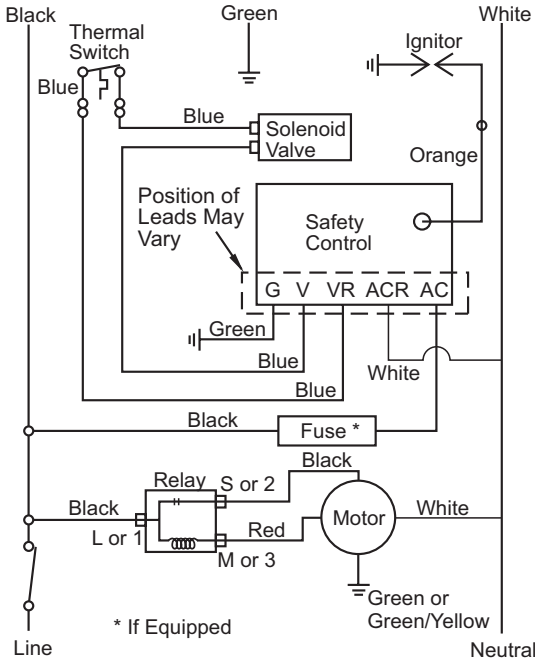

Note: Two different safety controls are used on the 155 model heaters. The wire leads have the same color and function on each, however, wire locations may be different.

Electrical Connection Diagram

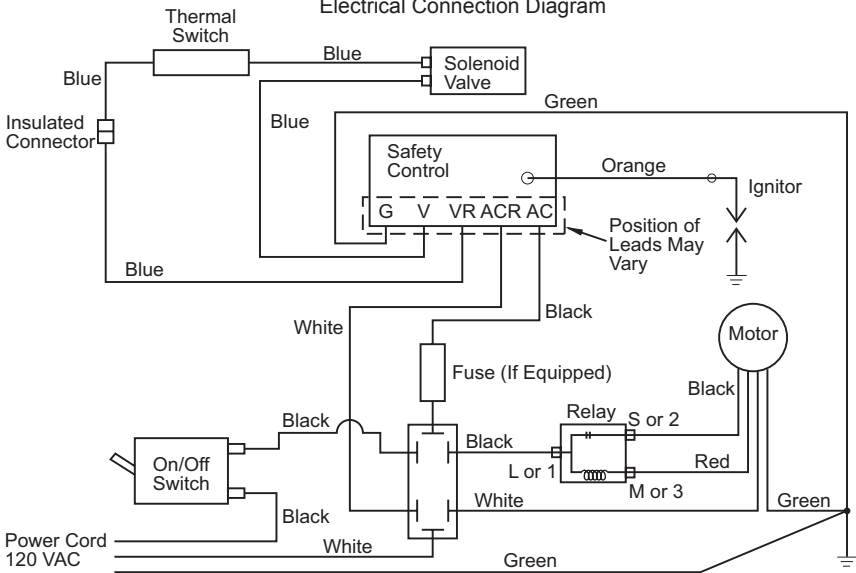

Wiring Diagrams, 155,000 Btu/hr

WIRING DIAGRAMS

Continued

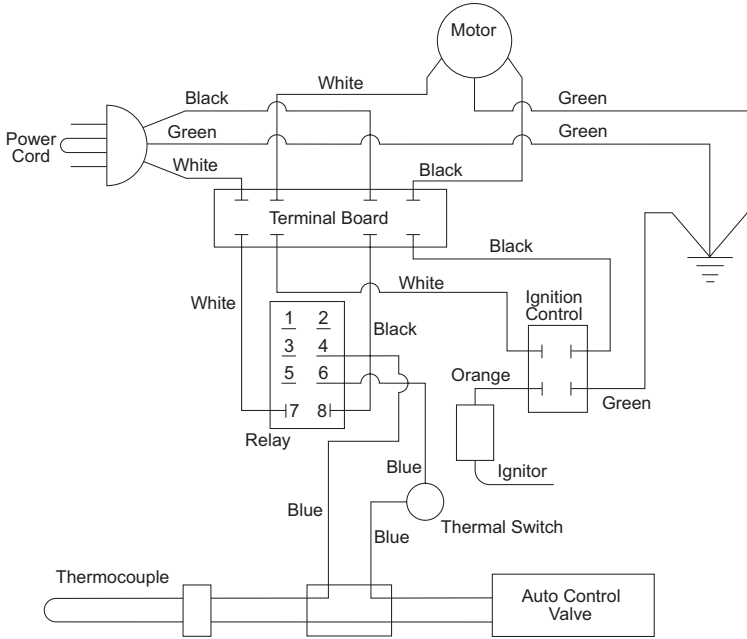

100,000 Btu/Hr Model

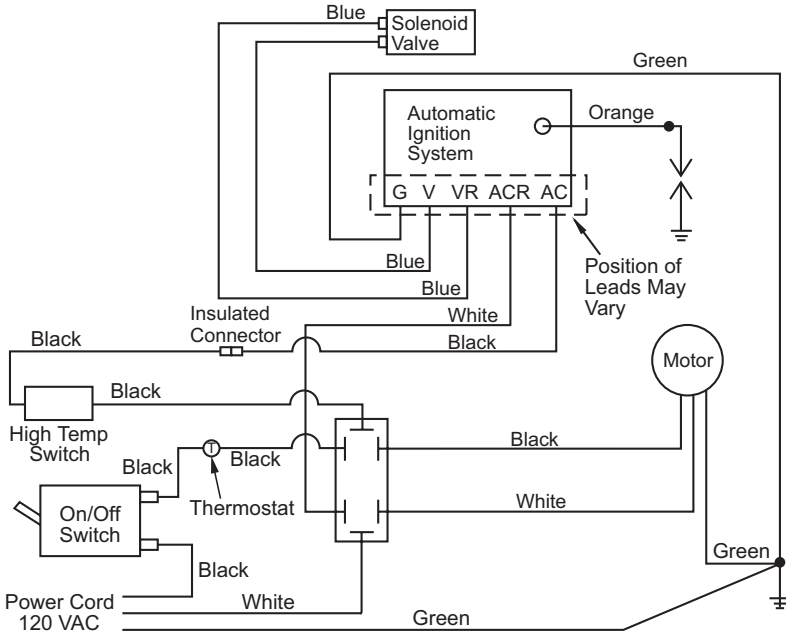

150,000 Btu/Hr Model

WIRING DIAGRAMS

Continued

Connection Diagram

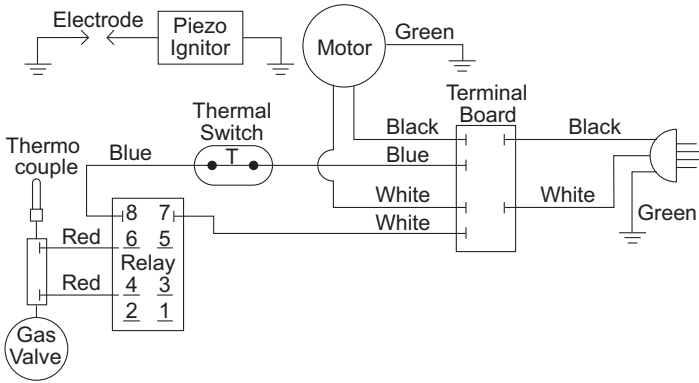

Electrical Ladder Diagram

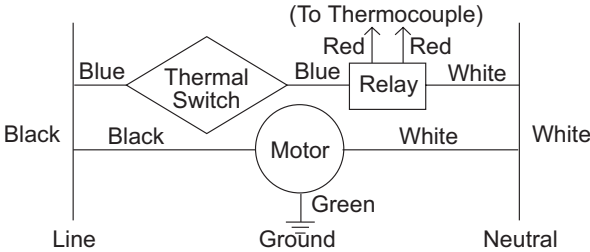

Wiring Diagrams 50,000 Btu/hr Models

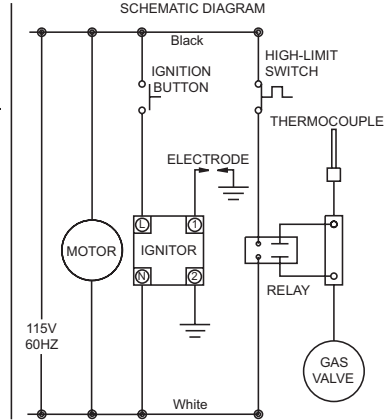
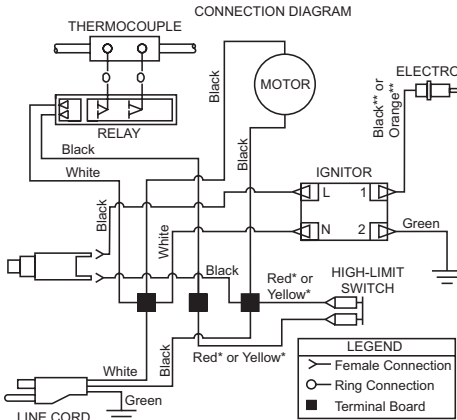

If any original wiring as supplied with the heater must be replaced, it must be replaced with type AWG 105° C wire or its equivalent except as indicated (*Type SF 2-200. **SGI-250° C)

Wiring Diagrams for 30-FAS and SPC-30

WIRING DIAGRAMS

Continued

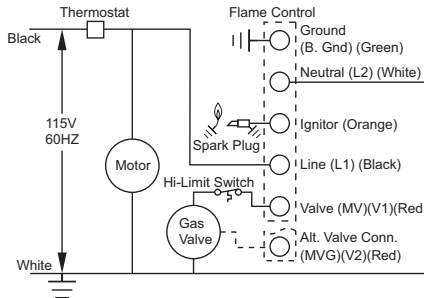
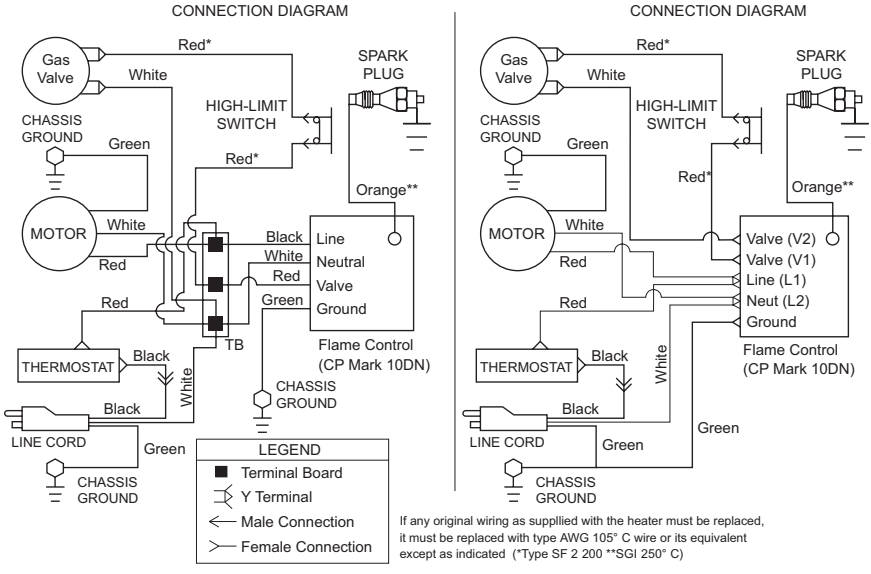

Wiring Diagrams for 150-F

WIRING CHART

150-F

Part No.	Color	Length	From	To
1041	White	4.5" (114 mm)	Terminal Block	Valve
1041	White	4.5" (114 mm)	Flame Control Valve	Valve
1226	Red (Hi-Temp)	16.5" (419 mm)	High Limit Switch	Valve
1226	Red (Hi-Temp)	16.5" (419 mm)	Terminal Block	High Limit Switch
1226	Red (Hi-Temp)	16.5" (419 mm)	Flame Control Valve	High Limit Switch
1188	Green	6" (152 mm)	Flame Control (Ground)	Ground
1111	Orange	8" (203 mm)	Flame Control (Ignition)	Spark Plug
1959	Green	7" (177 mm)	Flame Control (Harness)	Ground
1959	Red	7" (177 mm)	Flame Control (Harness)	Terminal Block
1959	White	6" (152 mm)	Flame Control (Harness)	Terminal Block
1959	Black	6" (152 mm)	Flame Control (Harness)	Terminal Block

WIRING DIAGRAMS

Continued

CONNECTION DIAGRAM

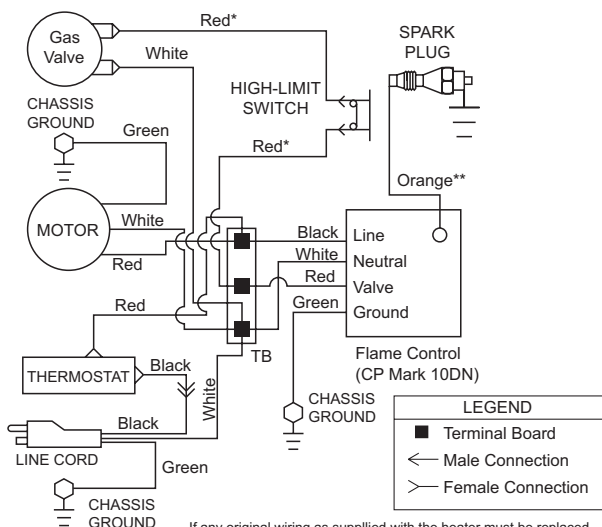

If any original wiring as supplied with the heater must be replaced, it must be replaced with type AWG 105° C wire or its equivalent except as indicated. (*Type SF 2-200 **SGI-250° C)

Wiring Diagrams for 170-F and SPC-170

WIRING CHART

170-F and SPC-170

Part No.	Color	Length	From	To
1100	White	7" (177 mm)	Valve	Terminal Block
1040	Black	6" (152 mm)	On/Off Switch	Terminal Block
1226	Red (Hi-Temp)	16.5" (419 mm)	High Limit Switch	Valve
1226	Red (Hi-Temp)	16.5" (419 mm)	High Limit Switch	Terminal Block
1070	Orange	11" (279 mm)	Flame Control (Ignition)	Spark Plug
1959	Green	7" (177 mm)	Flame Control (Harness)	Ground
1959	Red	7" (177 mm)	Flame Control (Harness)	Terminal Block
1959	White	6" (152 mm)	Flame Control (Harness)	Terminal Block
1959	Black	6" (152 mm)	Flame Control (Harness)	Terminal Block

ACCESSORIES AND SERVICE INFORMATION

ACCESSORIES

Purchase heater accessories and parts from your local dealer. If your dealer or service center cannot supply an accessory or part, contact your nearest Parts Central (listed in the separate Authorized Service Center booklet) or call DESA Heating Products' Parts Department at 1-866-672-6040. You can also write to the address listed on the back page of this manual.

Fuel Gas Connector - LPA4020

A POL adapter with excess-flow check valve.

Thermostat - HA1210 (only for models with DSI LP150)

- Helps economize on fuel
- No installation required
- Plugs into standard 120V outlet

TECHNICAL SERVICE

You may have further questions about this heater. If so, contact DESA Heating Products' Technical Service Department at 1-866-672-6040.

ILLUSTRATED PARTS LIST

Illustrated Parts List can be found in heater's owner's manual or visit www.desatech.com.

REPLACEMENT PARTS

Note: Use only original replacement parts. This will protect your warranty coverage for parts replaced under warranty.

Parts Under Warranty

Contact authorized dealers of this product. If they cannot supply original replacement part(s), either contact your nearest Parts Central or call DESA Heating Products' Technical Service Department at 1-866-672-6040.

When calling DESA Heating Products, have ready

- your name
- your address
- model number of your heater
- how heater was malfunctioning
- purchase date

In most cases, we will ask you to return the defective part to the factory.

Parts Not Under Warranty

Contact authorized dealers of this product. If they cannot supply original replacement part(s), either contact your nearest Parts Central or call DESA Heating Products' Technical Service Department at 1-866-672-6040.

When calling DESA Heating Products, have ready

- model number of your heater
- the replacement part number

DESA™
HEATING PRODUCTS

Technical Service Department

2701 Industrial Drive

P.O. Box 90004

Bowling Green, KY 42102-9004

www.desatech.com



099915 01
NOT A UPC

099915-01
Rev. B
11/04