

# **Series 255 Valve / 440i Control**

---

Water Conditioning Control System  
Installation, Operation and Maintenance Manual

## Table of Contents

Introduction .....	2	Adjustment of Brine Control .....	6
Superior Design		How to Set the Salt Dial	
Superior Operation		Removing the Series 255	
Installation .....	3	Control Module for Servicing .....	7
Location Selection		Preventive Maintenance .....	9
Water Line Connection		Specifications .....	10
Drain Line Connection		Pressure Graphs .....	11
Overflow Line Connection		Flow Diagrams .....	12
Electrical Connection		Replacement Parts .....	14
Increasing the Length of the Transformer Cord	4	Troubleshooting .....	18
Placing the Conditioner into Operation .....	5	Disinfection of Water Conditioners .....	19
Adjustment of Timer .....	6		
Special Features of Timer .....	6		

## Introduction

The Series 255 control system combines design simplicity with Noryl\* construction to provide the user with an uncommonly reliable appliance. The inherent reliability of the system means a long life of efficient, trouble-free, uninterrupted soft water luxury.

Should maintenance become necessary, the Series 255 offers a unique "separation" capability illustrated in this manual.

Of interest to both the owner and water conditioning dealer are the design and operation benefits detailed below.

## Superior Design

- **Fewer parts** than any control system of comparable function and most controls of lesser function.
- **Single synchronous low voltage electric motor** provides all the power for the clock 440i timer and the operation of the control.
- **Program clock (timer)** provides guest regeneration capability.
- **Control may be indexed manually with or without power** to its service or regeneration positions. Legend on timer faceplate indicates control valve position.
- **No moving parts in water stream** means no close tolerance components subject to fouling. Thus, the system is especially effective on iron-bearing water.
- **No dynamic seals** that could cause leakage through wear or fatigue.

- **Control accepts Noryl\* or brass manifold or modular bypass valve without modification**, offering complete versatility and easy plumbing for any installation.
- **Brining control valve built into system** eliminates need for an external brine valve.
- **Automatic drain controller** is incorporated in the system.

## Superior Operation

- **Direct acting system** functions independently of water pressure. No pistons or diaphragms that require a minimum water pressure to operate.
- **Five-cycle operation** provides for downflow service, upflow backwash, downflow brining, downflow rinse, downflow purge (fast rinse). A sixth position is included for timed refill of the brine tank.
- **Valve discs are held closed by water pressure** and therefore are leak tight. The sealing forces are increased as the water pressure is increased. Valve seats are in a vertical position, which is the design position least vulnerable to plugging.
- **System operation cannot get out of phase** or sequence. Control always returns to a fixed service position after regeneration regardless of where in the regeneration cycle it was started.
- **Bypass water is automatically available** during regeneration.

\*Noryl is a trademark of General Electric Company.

## Installation

All plumbing must conform to local codes.

Inspect unit carefully for carrier shortage or shipping damage.

## Location Selection

1. The distance between the unit and a drain should be as short as possible.
2. If it is likely that supplementary water treating equipment will be required, make certain adequate additional space is available.
3. Since salt must be added periodically to the brine tank, the location should be easily accessible.
4. Do not install any unit closer to a water heater than a total run of 10 feet (3 m) of piping between the outlet of the conditioner and the inlet to the heater. Water heaters can sometimes overheat to the extent they will transmit heat back down the cold pipe into the unit control valve.

Hot water can severely damage the conditioner. A 10-foot (3-m) total pipe run, including bends, elbows, etc., is a reasonable distance to help prevent this possibility. A positive way to prevent hot water from flowing from heat source to the conditioner, in the event of a negative pressure situation, is to install a check valve in the soft water piping from the conditioner. **If a check valve is installed, make certain the water heating unit is equipped with a properly rated temperature and pressure safety relief valve. Also, be certain that local codes are not violated.**

5. Do not locate unit where it or its connections (including the drain and overflow lines) will ever be subjected to room temperatures under 34°F (1°C) or over 120°F (49°C).
6. Do not install unit near acid or acid fumes.
7. The use of resin cleaners in an unvented enclosure is not recommended.

## Water Line Connection

The installation of a bypass valve system is recommended to provide for occasions when the water conditioner must be bypassed for hard water or for servicing.

The most common bypass systems are the Autotrol® Series 256 bypass valve (Figure 1) and plumbed-in globe valves (Figure 2). Though both are similar in function, the 256 Autotrol bypass offers simplicity and ease of operation.

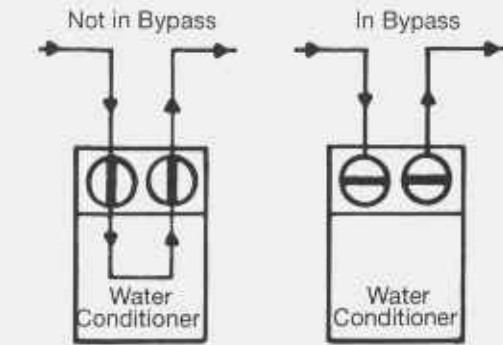

Figure 1 Autotrol Series 256 Bypass Valve

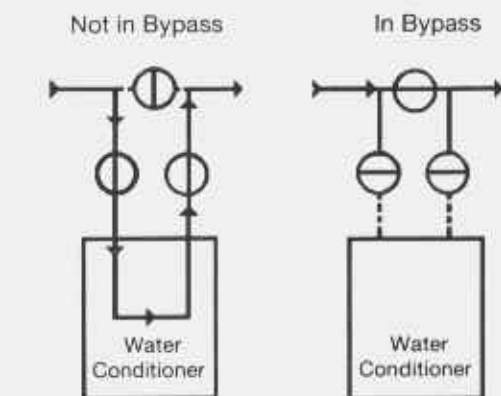

Figure 2 Typical Globe Valve Bypass System

## Drain Line Connection

1. Ideally located, the unit will be above and not more than 20 feet (6.1 m) from the drain. For such installations, using an appropriate adapter fitting (not supplied), connect 1/2-inch (1.3-cm) plastic tubing to the drain line connection of the control valve.
2. If the unit is located more than 20 feet (6.1 m) from drain, use 3/4-inch (1.9-cm) tubing for runs up to 40 feet (12.2 m). Also, purchase appropriate fitting to connect the 3/4-inch tubing to the 1/2-inch NPT drain connection.
3. If the unit is located where the drain line must be elevated, you may elevate the line up to 6 feet (1.8 m) providing the run does not exceed 15 feet (4.6 m) and water pressure at conditioner is not less than 40 psi (2.76 bar). You may elevate an additional 2 feet (61 cm) for each additional 10 psi (0.69 bar).
4. Where the drain line is elevated but empties into a drain below the level of the control valve, form a 7-inch (18-cm) loop at the far end of the line so that the bottom of the loop is level with the drain line connection. This will provide an adequate siphon trap.

- Where the drain empties into an overhead sewer line, a sink-type trap must be used.

**IMPORTANT:** Never insert drain line into a drain, sewer line or trap. Always allow an air gap between the drain line and the wastewater to prevent the possibility of sewage being back-siphoned into conditioner.

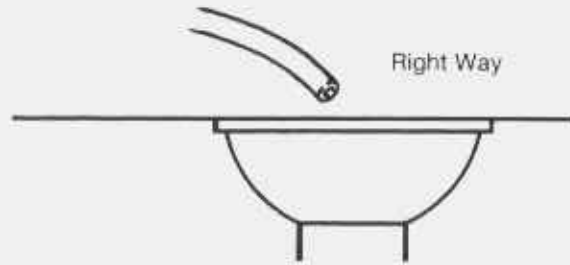

Figure 3

**Note:** Standard commercial practices have been expressed here. Local codes may require changes to these suggestions.

### Brine Line Connection

It will be necessary to install the brine tube and line to a fitting installed on the air check. Teflon\* tape all threaded connections.

Be sure all fittings and connections are tight so that premature checking does not take place. Premature checking is when the ball in the air check falls to the bottom before all brine is drawn out of the brine tank. See **Placing Conditioner into Operation** section.

### Overflow Line Connection

In the absence of a safety overflow and in the event of a malfunction, the BRINE TANK OVERFLOW will direct "overflow" to the drain instead of spilling on the floor where it could cause considerable damage. This fitting should be on the side of the cabinet or brine tank.

To connect overflow, locate hole on side of brine tank. Insert overflow fitting (not supplied) into tank and tighten with plastic thumb nut and gasket as shown (Figure 4). Attach length of 1/2-inch (1.3-cm) I.D. tubing (not supplied) to fitting and run to drain. Do not elevate overflow line higher than 3 inches (7.6 cm) below bottom of overflow fitting. Do not tie into drain line of control unit. Overflow line must be a direct, separate line from overflow fitting to drain, sewer or tub. Allow an air gap as per drain line instructions (Figure 3).

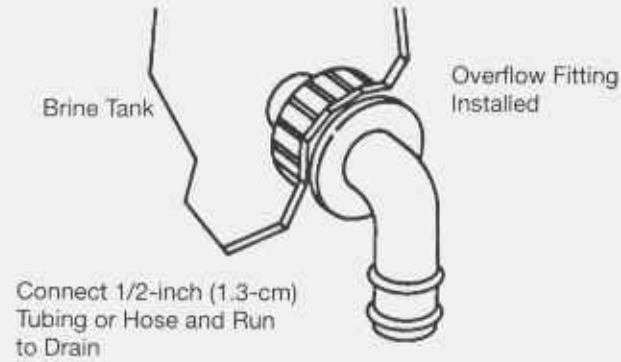

Figure 4

### Low Voltage Transformer

Only use the included transformer for powering the 440i timer. Connect the plug of the transformer secondary cable to the mating socket at the rear of the timer housing on the motor.

Be certain that the transformer is plugged into a correct voltage source that is not controlled by a wall switch.

### Increasing the Length of the Transformer Cord

If it is necessary to extend the length of the transformer cord, an optional 15-foot (4.6-m) extension is available (see Figure 5) or the cord may be spliced as follows:

- Strip insulation from wire 5/16 inch (8 mm) from wire end.
- Insert stripped wire into barrel of connector and crimp. For best results, crimp twice per wire as shown (Figure 6).

Splice connectors or extension wire is not supplied. They are available at hardware or electrical stores.



Figure 5

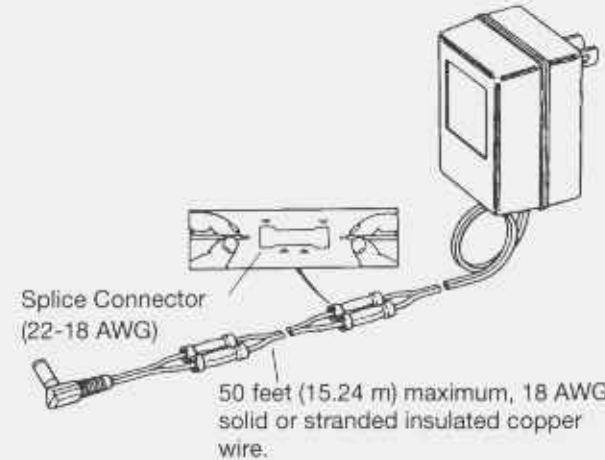

Figure 6

### Placing Conditioner into Operation

After all previous steps have been completed, the unit is ready to be placed into operation. Follow these steps carefully.

- Remove control valve cover (Figure 10).

**Note:** The following steps will require turning the pointer knob (Figure 8) to various positions. Insert a wide-blade screwdriver into arrow slot in pointer knob and press in firmly. With knob held in, rotate **COUNTERCLOCKWISE** only until arrow or knob points to desired position. (Rotation is made much easier if you grasp the camshaft with your free hand and turn it at the same time.) Then permit knob to spring back out.

- Insert screwdriver into slot in pointer knob (Figure 8). Press in and rotate knob **COUNTERCLOCKWISE** until arrow points directly to the word **BACKWASH**.
- Fill resin tank with water.
  - With water supply off, place the bypass valve(s) into the "not in bypass" position.
  - Open water supply valve very slowly to approximately the 1/4 open position.

**IMPORTANT:** If opened too rapidly or too far, resin may be lost. In this position, you should hear air escaping slowly from the drain line.

- When all of the air has been purged from the tank (water begins to flow steadily from the drain), open the water supply valve all the way.
- Allow water to run to drain until clear.
- Turn off water supply and let the unit stand for about five minutes. This will allow all trapped air to escape from the tank.

- Add water to brine tank (initial fill).  
With a bucket or hose, add approximately 4 gallons (15 liters) of water to brine tank. If the tank has a salt platform above the bottom of the tank, add water until the level is approximately 1 inch (25 mm) above the platform.

### Control Valve

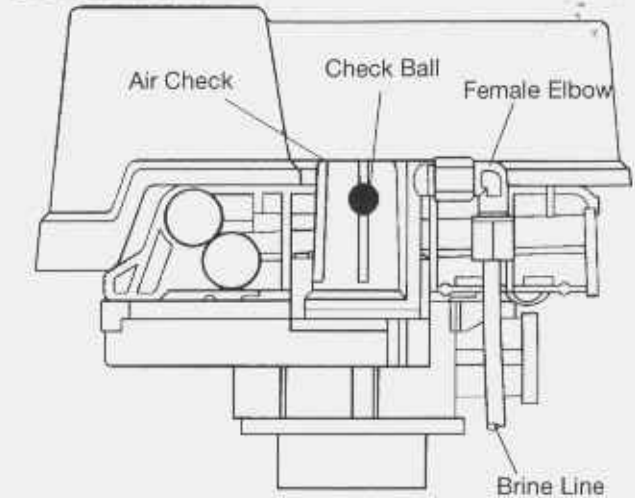

Figure 7 - Control Valve

- Put into operation.
  - Open water supply valve slowly to full open position.
  - Carefully advance pointer knob **COUNTERCLOCKWISE** to center of **FAST RINSE/REFILL** position and hold there until air check (Figure 7) fills with water and water starts to flow through brine line into brine tank. Do not run for more than two minutes.
  - Advance pointer knob **COUNTERCLOCKWISE** until arrow points to the center of the **BRINE/SLOW RINSE** position.
  - With the conditioner in this position, check to see if water is being drawn from the brine tank. The water level in the brine tank will recede very slowly. Observe for at least three minutes. If the water level does not recede or goes up, or if air enters the transparent air check chamber and the ball falls and seats, reference **Troubleshooting** section.
  - Advance pointer knob **COUNTERCLOCKWISE** to **CONDITIONED WATER**.
  - Run water from a nearby faucet until the water is clear and soft.

\* Teflon is a registered trademark of E.I. DePont de Nemours and Company, Inc.

## Adjustment of Timer

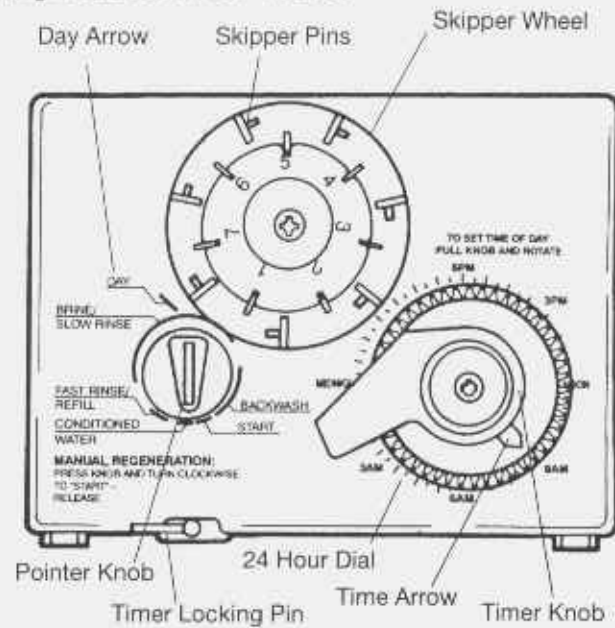

Figure 8

1. Set days of regeneration on skipper wheel (Figure 8).
  - Pull all skipper pins outward (away from control).
  - Rotate skipper wheel until day arrow points to current day or number 1.
  - Depress skipper pin(s) at day(s) for which regeneration is desired.
2. Set the time of day.
  - Grasp timer knob and pull outward.
  - Rotate in either direction until the timer arrow points to the actual time of day (Figure 8).
  - Release timer knob.

**Note:** With the time of day properly set, the conditioner will regenerate at about 2:30 a.m. If you prefer to have the unit regenerate at an earlier or later time, simply set current time-of-day accordingly (e.g., to have the unit **REGENERATE/BACKWASH** at 4:30 a.m.—2 hours later—set the clock two hours earlier than the actual current time.)

**Note:** The Timer Locking Pin should always be horizontal (Figure 8) during operation.

## Special Features of Timer

### Guest Cycle

When abnormally high water usage exhausts your water conditioner's capacity ahead of schedule, an extra regeneration can be achieved by depressing the pointer knob with a wide-blade screwdriver and turning **COUNTERCLOCKWISE** to **START** (Figure 8). It will take a few minutes for regeneration to start. Normal regeneration schedule will not be disrupted.

## Manual Regeneration

Electricity is used only to run the timer and to rotate the camshaft. All other functions are operated by water pressure. Therefore, in the event of a power outage, all the regeneration positions may be dialed manually by depressing the pointer knob and turning **COUNTERCLOCKWISE** (Figure 8). Manual time cycle: **BACKWASH**—14 minutes; **BRINE/SLOW RINSE**—52 minutes; **FAST RINSE/REFILL**—10 minutes. Do not exceed 10 minutes for the **FAST RINSE/REFILL** cycle as this will cause excessive salt usage during the next regeneration and possibly a salt residue in the softened water.

## Adjustment of Brine Control

All models may be adjusted to produce maximum to minimum conditioning capacities by setting the salt dial (Figure 9) which controls the amount of salt used per regeneration. When desired, the minimum setting may be used on installations if the frequency of regeneration is increased to compensate for the lower regenerated conditioning capacity. Your installing dealer will set your unit for proper salt usage. Further adjustments are needed only if water supply changes or if water use changes dramatically.

## How to Set Salt Dial

Insert screwdriver into slot of salt dial and move the pointer knob to proper salt setting (Figure 9).

**Note:** Using a screwdriver in the salt dial and turning the dial against one of the stops allows an easy means to assemble or disassemble the brine control from the valve. Reset the pointer window to the desired **LBS (of SALT)** after service and reinstallation are complete.

**Note:** To convert salt dial settings from English to metric, divide by 2.2 (e.g. 12 pounds ÷ 2.2 = 5.5 kg of salt).

The amount of salt placed into the regenerant storage tank has nothing to do with the amount of salt used during regeneration. Water will dissolve and absorb salt only until it becomes saturated. A given amount of brine (salt-saturated water) contains a specific amount of salt. The salt dial controls the amount of brine used during regeneration (e.g., when set at 15 pounds [6.8 kg]. The amount of brine the conditioner will use for each regeneration will contain 15 pounds [6.8 kg] of salt, etc.). Never let the amount of salt in the salt storage tank be lower than the normal liquid level.

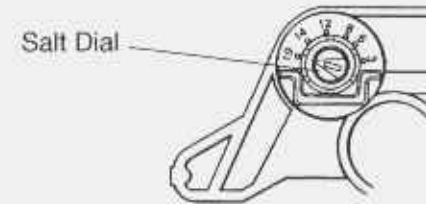

Figure 9

## Removing the Series 255 Control Module for Servicing

1. Unplug the transformer from the motor.
2. Shut off water supply or put bypass valve(s) into bypass position.
3. Remove cover (Figure 10), and with screwdriver, relieve tank pressure by pushing open the valve on control as shown (Figure 11).

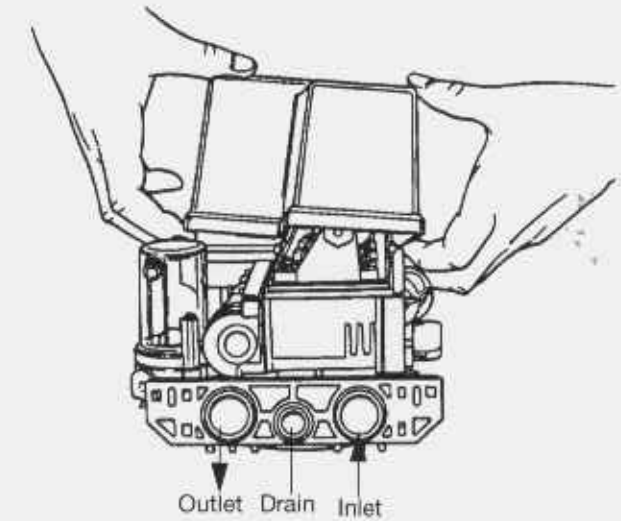

Figure 10

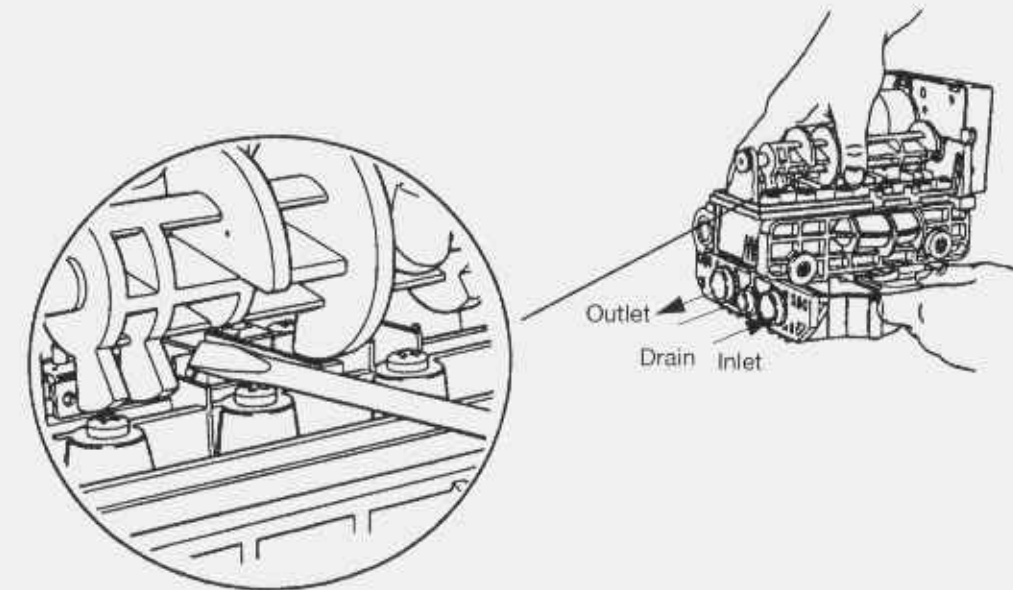

Figure 11

- Remove screw in locking bar (Figure 12).

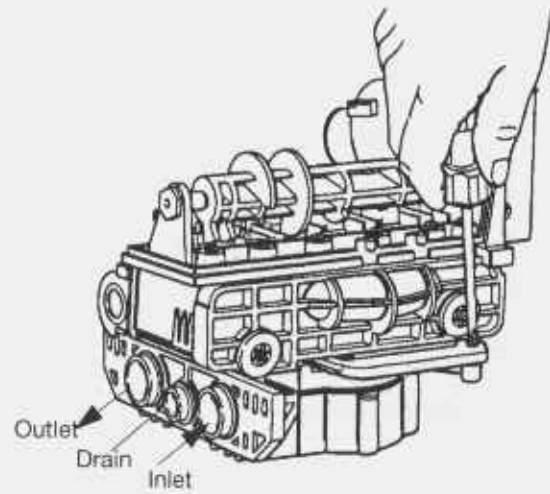

Figure 12

- Apply downward hand pressure on control and pull locking bar out (Figure 13).

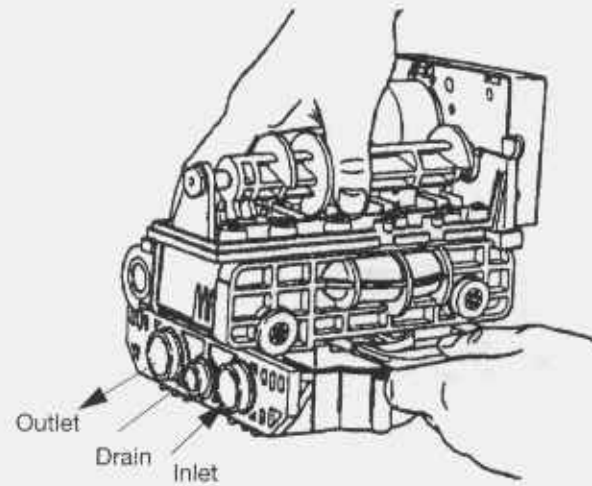

Figure 13

- Using a rocking motion, lift control from the tank adapter (Figure 14). If O-ring seals come off with control put them back into tank adapter sockets. Lubricate O-rings with silicone lubricant.

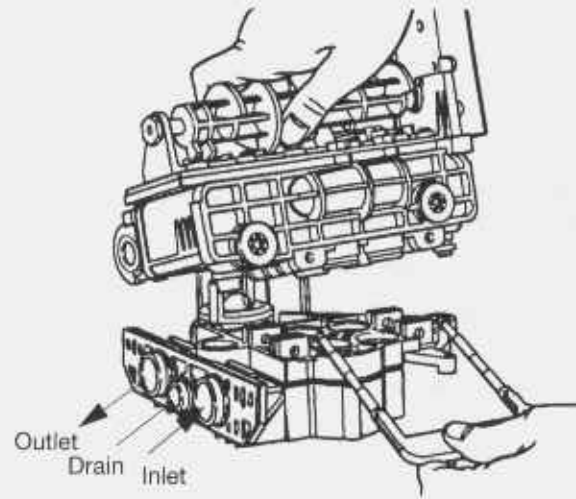

Figure 14

- To replace control module, reverse above procedure.

## Preventive Maintenance

Inspect and clean brine tank and screen filter on end of brine pickup tube once a year or when sediment appears in the bottom of the brine tank.

Clean injector screen and injector **once a year**:

- Unplug the wall-mount transformer.
- Shut off water supply or put bypass valve(s) into bypass position.
- Relieve system pressure by opening valve No. 5 (at rear) with a screwdriver (Figure 11).
- Using a screwdriver, remove injector screen and injector cap (Figure 15).
- Clean screen using a fine brush. Flush until clean.
- Using a needle-nose pliers, pull injector straight out.
- Flush water into the injector screen recess of the valve body to flush debris out through the injector recess.
- Clean and flush the injector.
- Lubricate the O-rings on the injector, injector cap and injector screen with silicone lubricant.
- Reinstall the injector, injector cap and injector screen. See **IMPORTANT** note.

- Plug the wall-mount transformer into outlet; reset time of day.
- Slowly open water supply valve or return bypass valve(s) to the "not in bypass" position.

**IMPORTANT:** Do not overtighten the plastic cap. Seat the cap lightly into position. Overtightening may cause breakage of the plastic cap that may not be immediately evident.

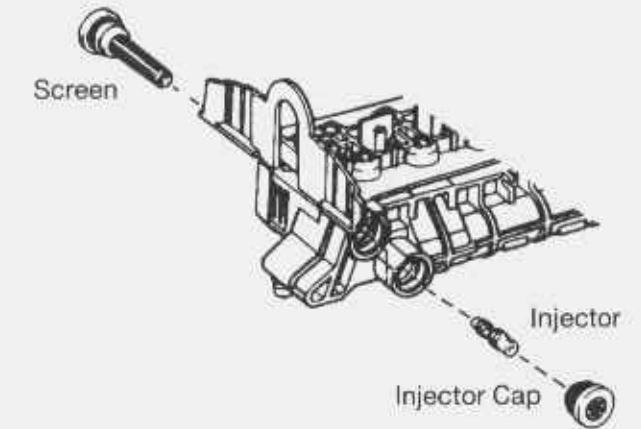
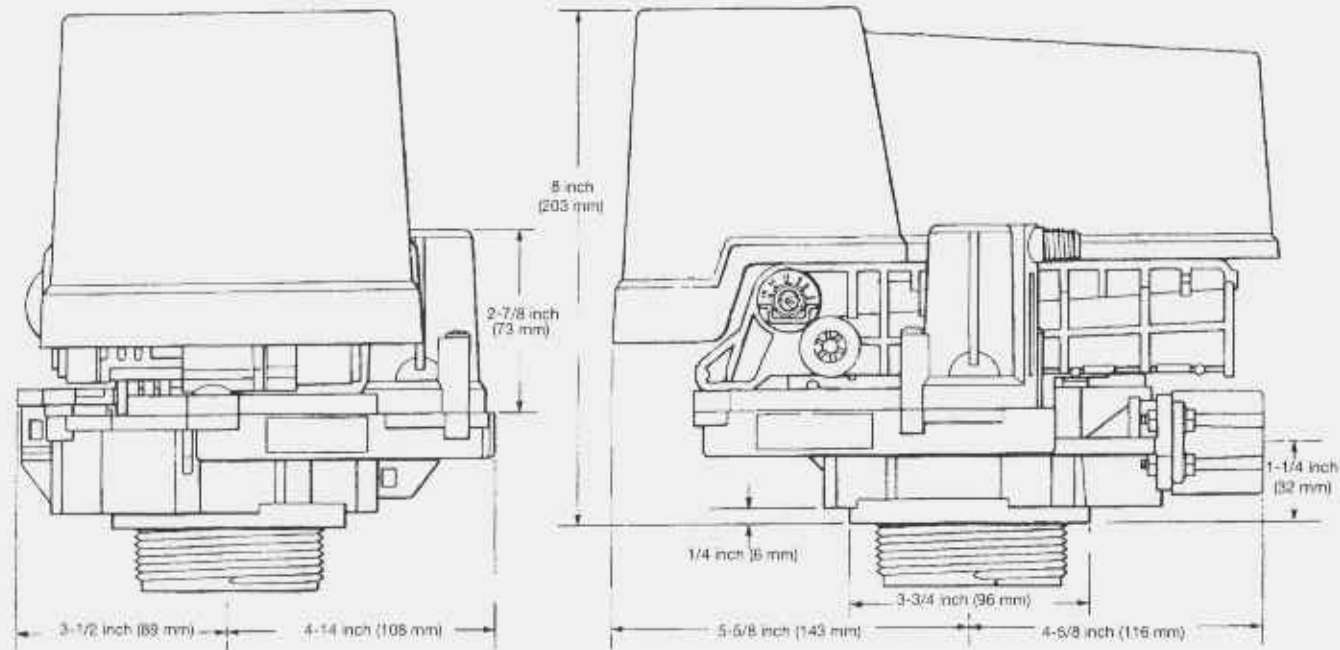

Figure 15

## Specifications



Hydrostatic Test Pressure .....	300 psi (20.69 bar)
Working Pressure .....	20-127 psi (1.39 - 8.76 bar)
Standard 12 Volt Transformer Input Electrical Rating .....	115V 60 Hz
Optional 12 Volt Transformer Input Electrical Rating .....	115V 50 Hz, 230V 50 Hz, 230V 60 Hz, 100V 60 Hz, 100V 50 Hz
Transformer Cord .....	120 inch (3.048 m)
Pressure Tank Thread .....	2 1/2 inch-8 male
Brine Line Thread .....	1/4-inch NPT male
Distributor Tube Diameter Required .....	13/16 inch OD (20.6 mm)
Distributor Tube Length .....	.1 1/4 inches (31.8-mm) higher than top of mineral tank
Inlet-Outlet Manifold (Brass or Noryl) .....	3/4-inch NPT, 1-inch NPT, 3/4-inch BSPT, 1-inch BSPT
Optional Bypass Valve, Control Module, Tank Adapter .....	Reinforced Noryl
Rubber Goods .....	Compounded for cold water service
Brine Refill Control .....	1 to 10 lbs (0.45 to 4.5 kg) of salt or 3 to 19 lbs (1.4 to 8.6 kg) of salt
Injector Size "A" White .....	Nozzle .042-inch (1.1-mm) Diameter, Throat .089-inch (2.3-mm) Diameter
Injector Size "B" Blue .....	Nozzle .052-inch (1.3-mm) Diameter, Throat .099-inch (2.5-mm) Diameter
Injector Size "C" Red .....	Nozzle .059-inch (1.5-mm) Diameter, Throat .099-inch (1.5-mm) Diameter
Backwash Controllers Available for .....	7, 8, 9, 10, 12, 13, 14 inch (17.8, 20.3, 22.9, 25.4, 30.5, 33.0, 35.6 cm) diameter mineral tanks. All are sized to flow 4.5 gpm/sq ft (183 L/m <sup>2</sup> of bed area).

Backwash Number	7	8	9	10	12	13	14
Flow (gpm*)	1.2	1.6	2.0	2.5	3.5	4.1	4.8
Flow (Lpm*)	4.5	6.0	7.6	9.5	13.2	15.5	18.2

\*Approximate flow rates at 60 psi (4.14 bar)

## Pressure Graphs

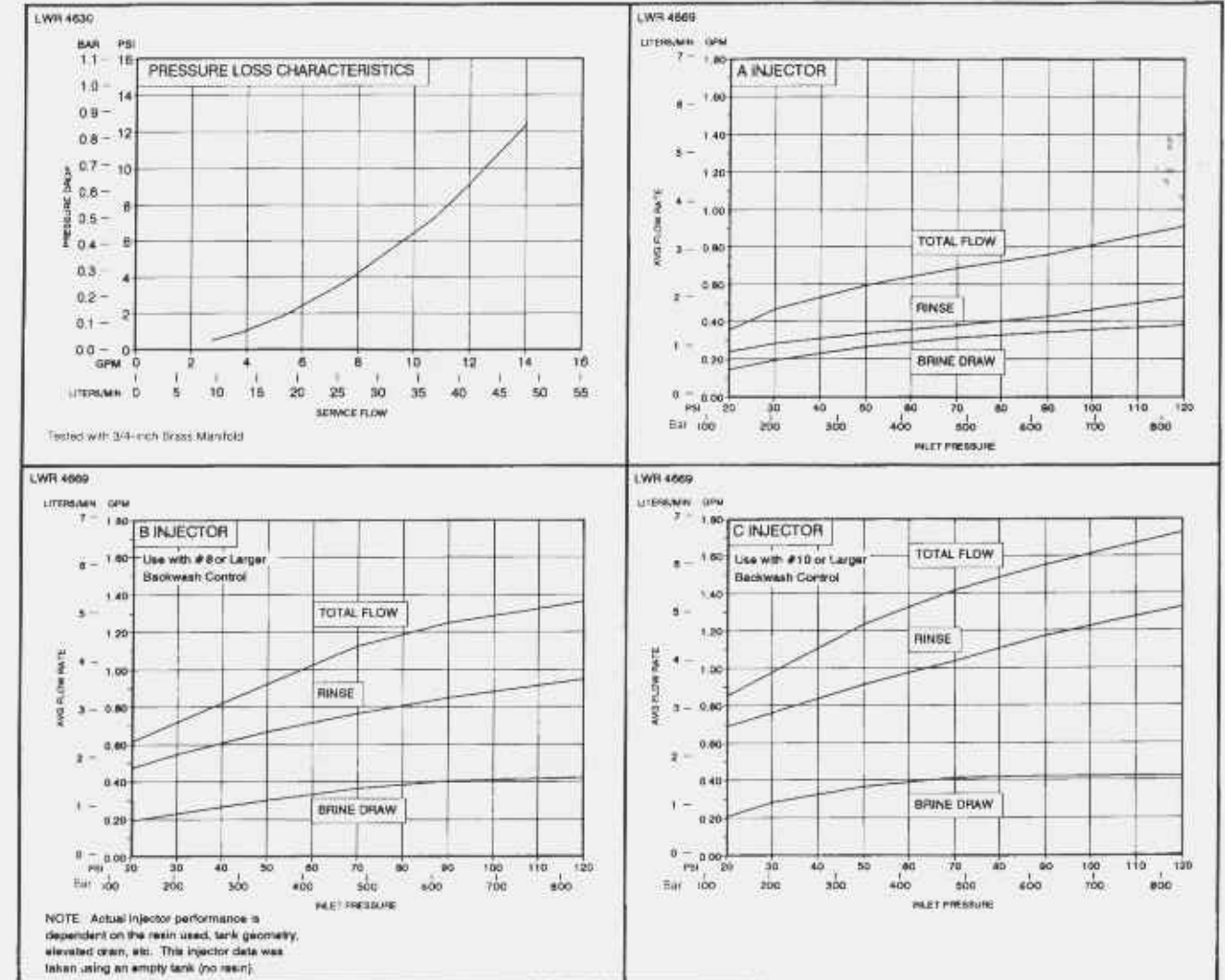

## Identification of Control Valving

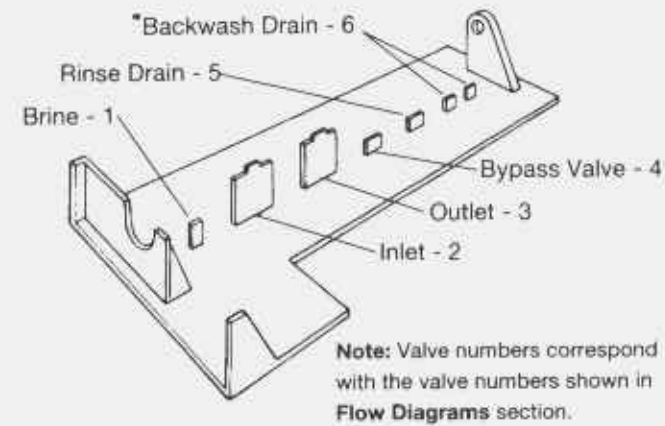

## Valve Disc Principle of Operation

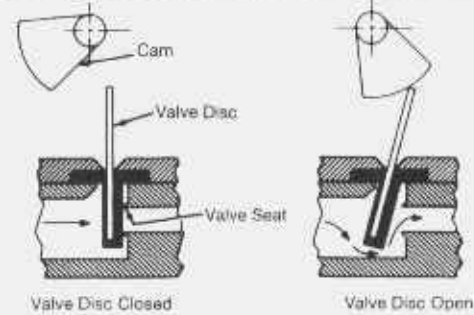

## Flow Diagrams

### 1 Service Position

□ Hard Water  
■ Soft Water

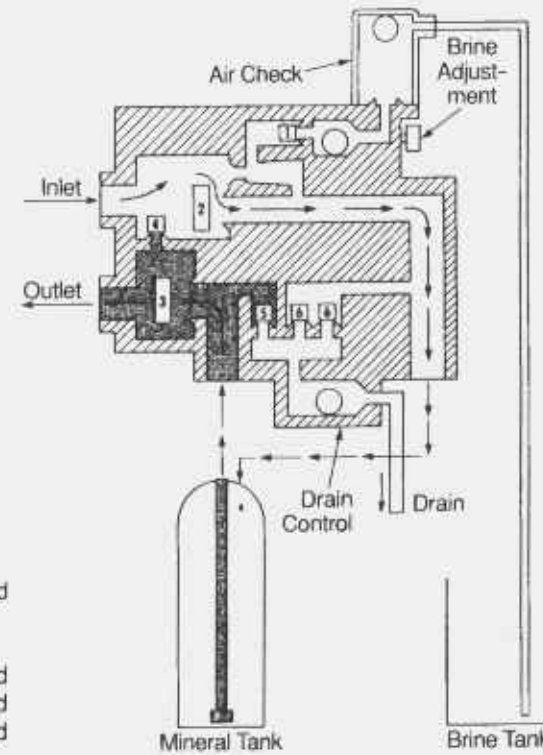

### 2 Backwash Position

□ Hard Water  
■ Backwash

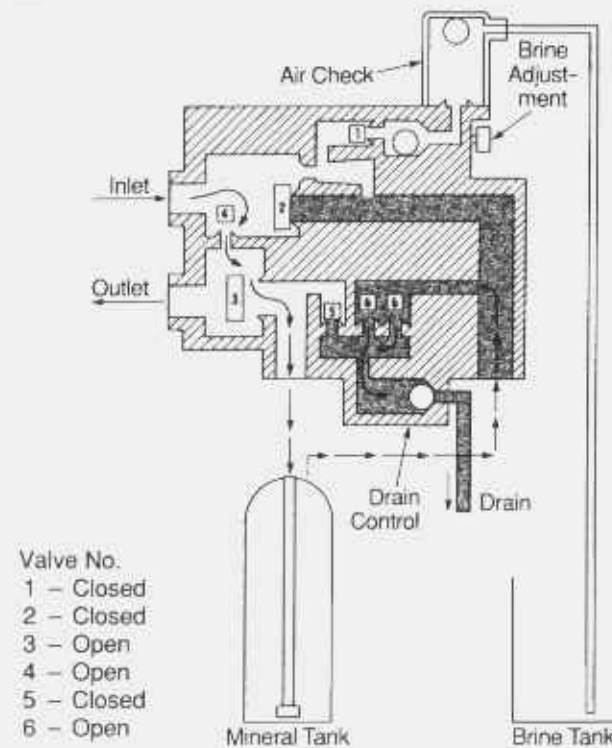

### 3 Brining Position

□ Hard Water  
■ Brine

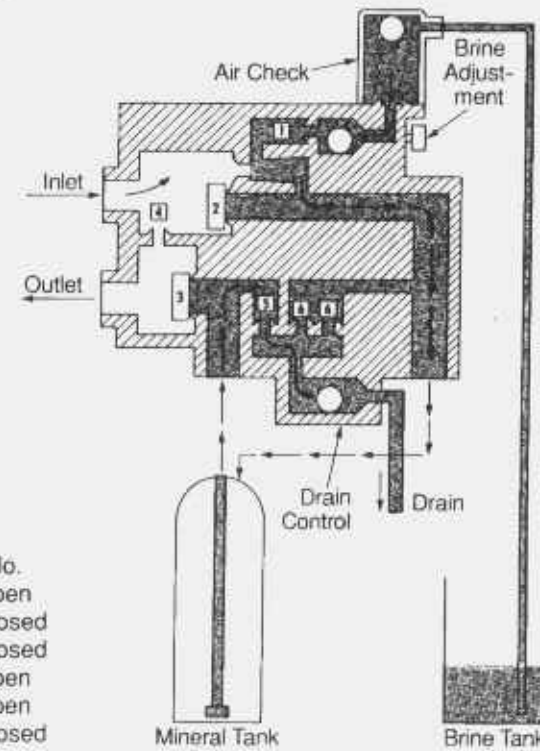

### 4 Slow Rinse Position

□ Hard Water  
■ Brine

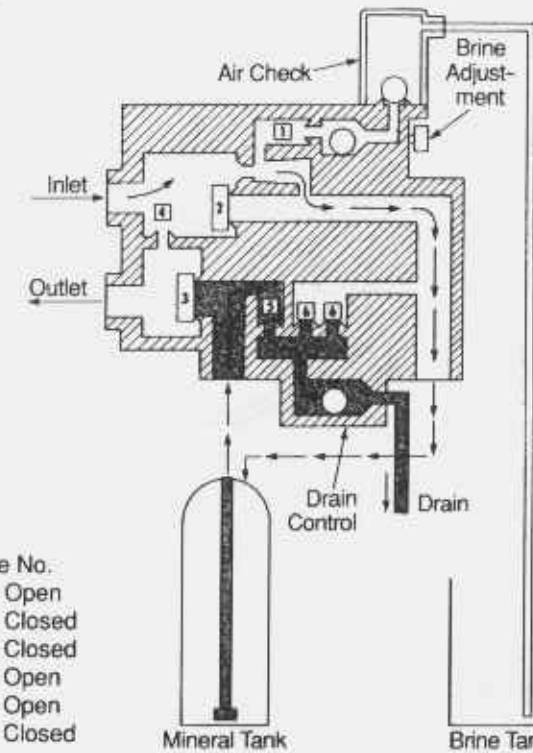

### 5 Brine Refill and Purge Position

□ Hard Water  
■ Soft Water

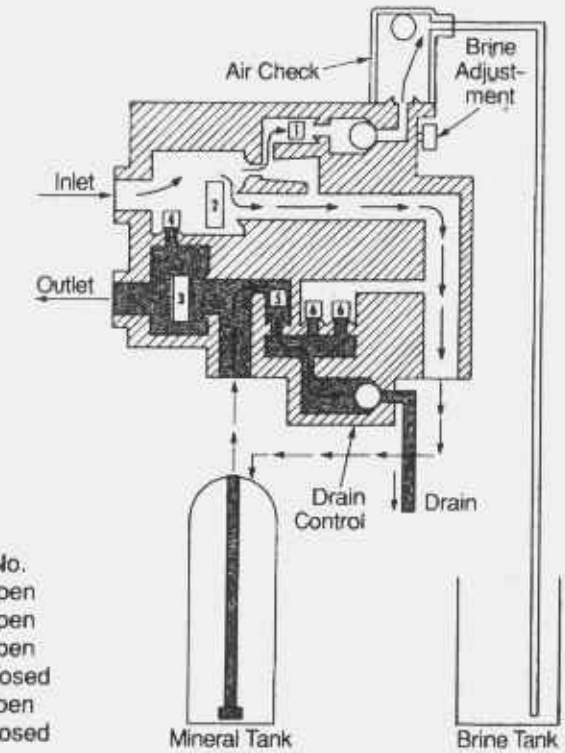

## Replacement Parts

### Valve Body

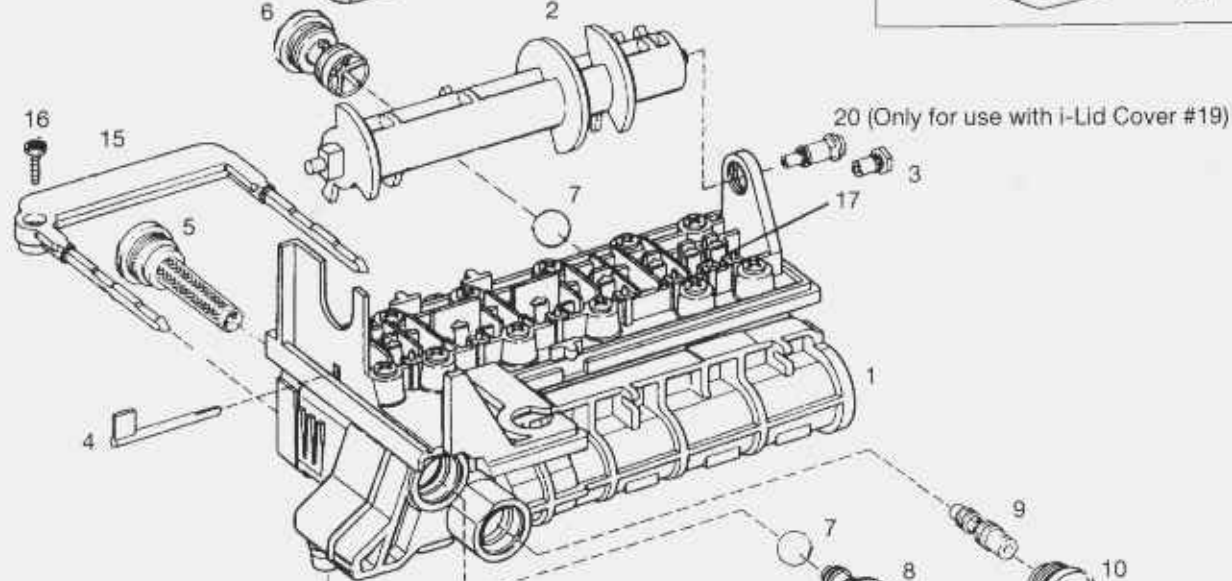
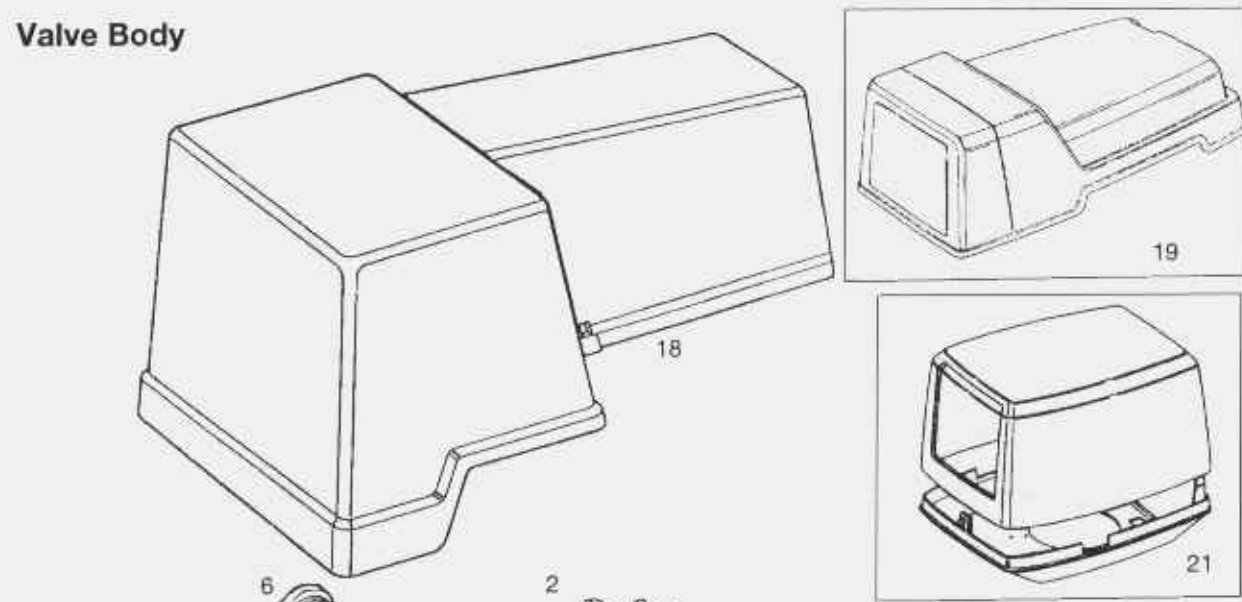

### Tank Adapter Module

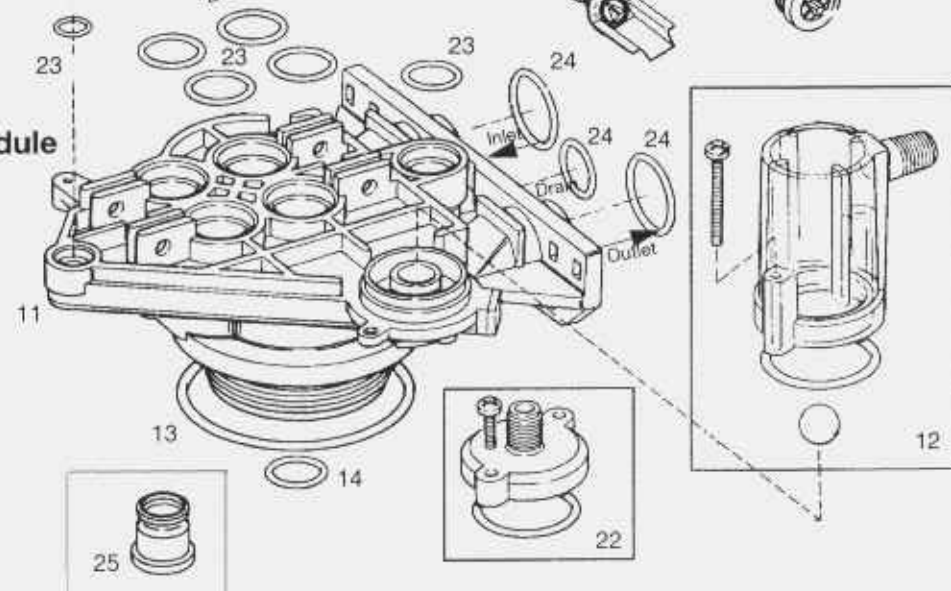

## Valve

Code	Part No.	Description	Qty.	Code	Part No.	Description	Qty.
1	1000232	Valve Assembly, w/o Flow Controls	1	13	1010429	O-Ring BN	1
2		Camshaft:	1	14	1010428	O-Ring EP	1
	1031950	Standard, One-Piece		15		Locking Bar:	1
	1033024	Standard, Segmented			1031402	English Language	
	1033025	Extra Salt, Segmented			1031403	French Language	
	1033026	Long Rinse, Segmented			1031404	German Language	
	1032969	Water Saver, Segmented			1031405	Italian Language	
3	1030501	Camshaft Bearing	1		1031406	Japanese Language	
4	1031391	Timer Locking Pin	1		1031407	Spanish Language	
5	1000226	Screen/Cap Assembly w/O-Ring	1	16	1006093	Screw, No. 8 x 9/16 inch	1
6		Drain Control Assembly w/O-Rings:	1	17	1001580	Spring, Valve Discs	9
	1000209	No. 7 (1.2 gpm; 4.5 Lpm)		18	1032565	Valve Cover, Standard, Black	1
	1000210	No. 8 (1.6 gpm; 6.1 Lpm)		19	1000062	i-Lid Cover	1
	1000211	No. 9 (2.0 gpm; 7.6 Lpm)		20	1000297	Extended Connector (For use with i-Lid Cover)	1
	1000212	No. 10 (2.5 gpm; 9.5 Lpm)		21		High Style Covers:	
	1000213	No. 12 (3.5 gpm; 13.2 Lpm)			1042087	Beige/Brown	
	1000214	No. 13 (4.1 gpm; 15.5 Lpm)**			1041088	Black/White	
	1000215	No. 14 (4.8 gpm; 18.2 Lpm)**			1041091	Beige/Black	
7	1030502	Ball, Flow control	2			Kits:	
8		Brine Refill Control:	1	22	1033066	New To Old Aircheck Adapter	
	1034261	1 to 10 lbs Salt		23	1010404	O-Ring Group: Tank Adapter 1010117 (1), 1010407 (1), 1010410 (4)	
	1034263	3 to 19 lbs Salt		24	1040459	O-Ring Group: Piping Boss 1010431 (1), 1010411 (2)	
9		Injector Assembly with O-Rings:	1	25	1041010	13/16 Rubber Insert (Optional)	
	1032970	"A" Injector - White				Valve Discs:	
	1032971	"B" Injector - Blue		*	1000250	Standard	
	1092972	"C" Injector - Red		*	1000252	Severe Service	
10		Injector Cap with O-Ring:	1				
	1000217	"A" Cap					
	1000218	"B" Cap					
	1000219	"C" Cap					
11	1033784	Tank Adapter Assembly	1				
12	1032416	Air Check Kit	1				

\* Not Shown

\*\*Flow control does not use Flow Control Ball (1030502).

## 440i Timer

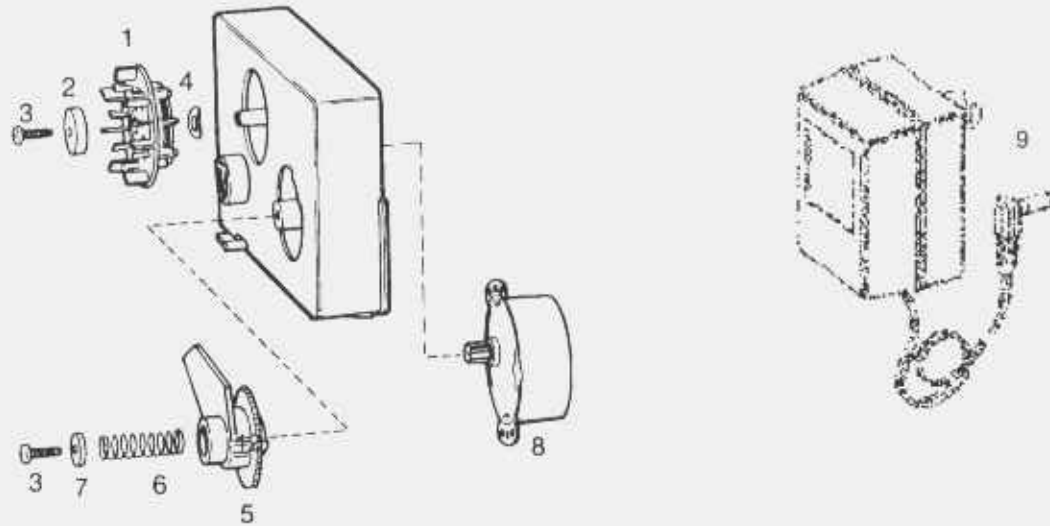

## Bypass Valve

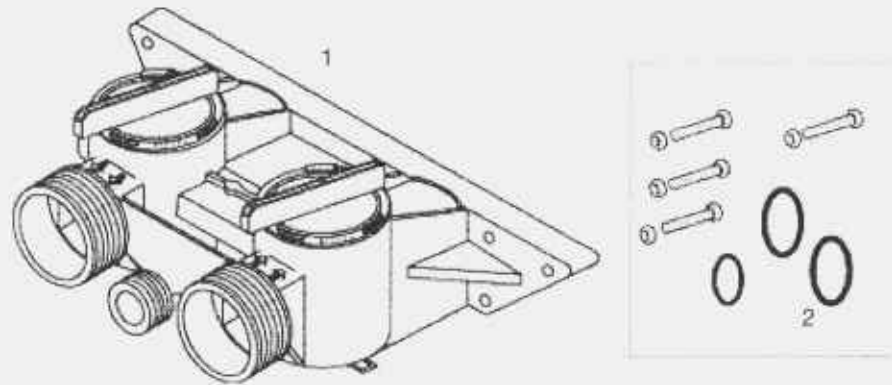

## Piping Boss

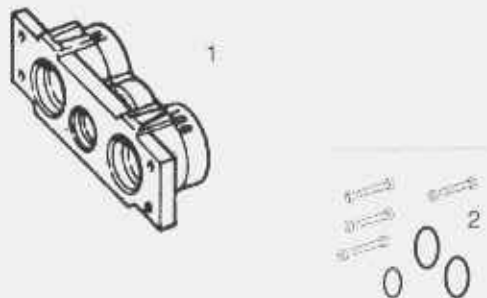

**Note:** Do not use pipe joint compound when threading pipe into the Noryl piping boss. Use only Teflon pipe tape. Do not overtighten pipe into Noryl piping boss.

## 440i Timer

Code	Part No.	Description	Qty.
1		Skipper Wheel Assembly:	1
	1031740	6-Day	
	1031742	7-Day	
2	1030659	Washer	1
3	1006091	Screw, No. 6 x 1/2 inch	2
4	1006601	Bowed Washer	1
5	1031756	Tripper Arm Assembly	1
6	1030830	Spring	1
7	1030821	Retainer	1
8	1001569	Motor, 12 Volt, 60 Hz	1
9		Transformer:	
	1000810	Japanese	
	1000811	North American	
	1000812	Australian	
	1000813	British	
	1000814	European	
*	1000907	Transformer Extension Cord 15 feet (4.6 m)	1

## Piping Boss

1		Piping Boss Kit (includes Hardware):	1
	1040277	3/4-inch NPT, Brass, 3/8-inch NPT Drain	
	1040278	1-inch NPT, Brass, 1/2-inch NPT Drain	
	1040281	3/4-inch BSPT, Brass, 3/8-inch BSPT Drain	
	1040282	1-inch BSPT, Brass, 1/2-inch BSPT Drain	
	1040279	3/4-inch NPT, Noryl, 1/2-inch NPT Drain	
	1040280	1-inch NPT, Noryl, 1/2-inch NPT Drain	
	1040283	3/4-inch BSPT, Noryl, 1/2-inch BSPT Drain	
	1040284	1-inch BSPT, Noryl, 1/2-inch BSPT Drain	
2	1040339	Piping Boss installation Kit	1

\*Not Shown

## Bypass Valve

Code	Part No.	Description	Qty.
1	1040769	Bypass Body Assembly	1
2	1040524	Bypass Installation Kit	1
		Service Kits:	
*	1034301	Rotor Replacement	
*	1034302	Kit, Service, Rotor Seals and Two Clips	
*	1034303	24 pk, Rotor Clips	

## Tube Adapter Kits

*	1001606	3/4-inch Copper Tube Adapter Kit	1
*	1001670	1-inch Copper Tube Adapter Kit	1
*	1001608	22-mm Copper Tube Adapter Kit	1
*	1001609	28-mm Copper Tube Adapter Kit	1
*	1001613	3/4-inch CPVC Tube Adapter Kit	1
*	1001614	1-inch CPVC Tube Adapter Kit	1
*	1001615	25-mm CPVC Tube Adapter Kit	1
*	1001769	3/4-inch NPT Plastic Pipe Adapter Kit	1
*	1001603	1-inch NPT Plastic Pipe Adapter Kit	1
*	1001604	3/4-inch BSPT Plastic Pipe Adapter Kit	1
*	1001605	1-inch BSPT Plastic Pipe Adapter Kit	1
*	1001611	3/4-inch BSPT Brass Pipe Adapter Kit	1
*	1001610	1-inch NPT Brass Pipe Adapter Kit	1
*	1001612	1-inch BSPT Brass Pipe Adapter Kit	1

## Troubleshooting

The technology upon which the Series 255 control is based is well established and proven in service over many years. However, should a problem or question arise regarding the operation of the system, the control can be very easily serviced. The control module can be

quickly replaced or adjustments can be made at the installation. For parts mentioned, refer to exploded views in the **Replacement Parts** section of this manual.

Problem	Possible Cause	Solution
1. Control will not regenerate automatically.	<ul style="list-style-type: none"> <li>a. Transformer or motor not connected.</li> <li>b. Defective timer motor.</li> <li>c. Skipper pins not down on timer skipper wheel.</li> <li>d. Binding in gear train of timer.</li> </ul>	<ul style="list-style-type: none"> <li>a. Connect power.</li> <li>b. Replace motor.</li> <li>c. Depress pins for days regeneration required.</li> <li>d. Replace timer.</li> </ul>
2. Control regenerates at wrong time of day.	<ul style="list-style-type: none"> <li>a. Timer set incorrectly.</li> </ul>	<ul style="list-style-type: none"> <li>a. Correct time setting according to instructions.</li> </ul>
3. Control will not draw brine.	<ul style="list-style-type: none"> <li>a. Low water pressure.</li> <li>b. Restricted drain line.</li> <li>c. Injector plugged.</li> <li>d. Injector defective.</li> <li>e. Valve disc 2 and/or 3 not closed.</li> <li>f. Air check valve closes prematurely.</li> <li>g. Timer locking pin not horizontal.</li> </ul>	<ul style="list-style-type: none"> <li>a. Set pump to maintain 20 psi at softener.</li> <li>b. Change drain to remove restriction.</li> <li>c. Clean injector and screen.</li> <li>d. Replace injector.</li> <li>e. Remove foreign matter from disc and check disc for closing by pushing in on stem. Replace if needed.</li> <li>f. Put control momentarily into brine/slow rinse. Replace or repair air check if needed.</li> <li>g. Turn to horizontal position.</li> </ul>
4. Brine tank overflow.	<ul style="list-style-type: none"> <li>a. Brine valve disc 1 being held open by foreign matter.</li> <li>b. Uncontrolled brine refill flow rate.</li> <li>c. Valve disc 2 not closed during brine draw causing brine refill.</li> <li>d. Air leak in brine line to air check.</li> <li>e. Improper drain control for injector.</li> <li>f. Drain control clogged with resin or other debris.</li> </ul>	<ul style="list-style-type: none"> <li>a. Manually operate valve stem to flush away obstruction.</li> <li>b. Remove brine control to clean ball and seat.</li> <li>c. Flush out foreign matter holding disc open by manually operating valve stem.</li> <li>d. Check all connections in brine line for leaks. Refer to instructions.</li> <li>e. Too small of a drain control with a "B" or "C" injector will reduce draw rates. See <b>Pressure Graphs</b>.</li> <li>f. Clean drain control.</li> </ul>
5. System using more or less salt than salt dial setting.	<ul style="list-style-type: none"> <li>a. Foreign matter in controller causing incorrect flow rates.</li> <li>b. Defective controller.</li> </ul>	<ul style="list-style-type: none"> <li>a. Remove brine control and flush out foreign matter. Manually position control to brine/slow rinse to clean controller (after so doing position control to "purge" to remove brine from tank).</li> <li>b. Replace brine control.</li> </ul>
6. Intermittent or irregular brine draw.	<ul style="list-style-type: none"> <li>a. Low water pressure.</li> <li>b. Defective injector.</li> </ul>	<ul style="list-style-type: none"> <li>a. Set pump to maintain 20 psi at softener.</li> <li>b. Replace injector.</li> </ul>
7. No conditioned water after regeneration.	<ul style="list-style-type: none"> <li>a. No salt in brine tank.</li> <li>b. Injector plugged.</li> <li>c. Air check valve closes prematurely.</li> </ul>	<ul style="list-style-type: none"> <li>a. Add salt to brine tank.</li> <li>b. Clean injector and screen.</li> <li>c. Put control momentarily into brine/slow rinse. Replace or repair air check if needed.</li> </ul>

Problem	Possible Cause	Solution
8. Control backwashes or purges at excessively low or high rate.	<ul style="list-style-type: none"> <li>a. Incorrect drain controller used.</li> <li>b. Foreign matter affecting controller operation.</li> </ul>	<ul style="list-style-type: none"> <li>a. Replace with correct size controller.</li> <li>b. Remove drain controller and clean ball and seat.</li> </ul>
9. Flowing or dripping water at drain or brine line after regeneration.	<ul style="list-style-type: none"> <li>a. Drain valve (5 or 6) or brine valve (1) held open by foreign matter or particle.</li> <li>b. Valve stem return spring weak.</li> </ul>	<ul style="list-style-type: none"> <li>a. Manually operate valve stem to flush away obstruction.</li> <li>b. Replace spring.</li> </ul>
10. Hard water leakage after regeneration.	<ul style="list-style-type: none"> <li>a. Improper regeneration.</li> <li>b. Leaking of external bypass valve.</li> <li>c. O-ring around riser pipe damaged.</li> <li>d. Leaking past bypass valve disc.</li> </ul>	<ul style="list-style-type: none"> <li>a. Repeat regeneration making certain correct salt dosage was set.</li> <li>b. Replace O-ring.</li> <li>c. Replace O-ring.</li> <li>d. Replace valve disc.</li> </ul>

## Disinfection of Water Conditioners

The materials of construction of the modern water conditioner will not support bacterial growth, nor will these materials contaminate a water supply. However, the normal conditions existing during shipping, storage and installation indicate the advisability of disinfecting a conditioner after installation, before the conditioner is used to treat potable water. In addition, during normal use, a conditioner may become fouled with organic matter, or in some cases with bacteria from the water supply.

Thus every conditioner should be disinfected after installation, some will require periodic disinfection during their normal life, and in a few cases disinfection with every regeneration would be recommended.

Depending upon the conditions of use, the style of conditioner, the type of ion exchanger, and the disinfectant available, a choice can be made among the following methods.

### Sodium or Calcium Hypochlorite

#### Application

These materials are satisfactory for use with polystyrene resins, synthetic gel zeolite, greensand and bentonites.

#### 5.25% Sodium Hypochlorite

These solutions are available under trade names such as Clorox, Linco, Bo Peep, White Sail and Eagle Brand Bleach. If stronger solutions are used, such as those sold for commercial laundries, adjust the dosage accordingly.

#### 1. Dosage

- a. Polystyrene resin; 1.2 fluid ounce per cubic foot.
- b. Non-resinous exchangers; 0.8 fluid ounce per cubic foot.

#### 2. Brine tank conditioners

- a. Backwash the conditioner and add the required amount of hypochlorite solution to the brine well of the brine tank. (The brine tank should have water in it to permit the solution to be carried into the conditioner.)
- b. Proceed with the normal regeneration.

### Calcium Hypochlorite

Calcium hypochlorite, 70% available chlorine, is available in several forms including tablets and granules. These solid materials may be used directly without dissolving before use.

#### 1. Dosage

- a. Two grains (approximately 0.1 ounce) per cubic foot.

#### 2. Brine tank conditioners

- a. Backwash the conditioner and add the required amount of hypochlorite to the brine well of the brine tank. (The brine tank should have water in it to permit the chlorine solution to be carried into the conditioner.)
- b. Proceed with the normal regeneration.