

PARTS LIST			
ITEM	PART NO.	DESCRIPTION	QTY.
1	A	2x4x18 11/16 w/ 8° cut	2
2	B	2x4x24 w/ 8° cut	1
3	C	2x4x24	1
4	D	2x4x31 w/ 8° cut	2
5	E	2x4x32 3/16 w/30° & 52° cuts	2
6	F	2x4x36	2
7	G	2x6x24	2
8	Caster	2 1/2" Caster	4
9	Bolt	5/16"x1" Lag Screw	16
10	Screw	2 1/2" Deck Screws	60

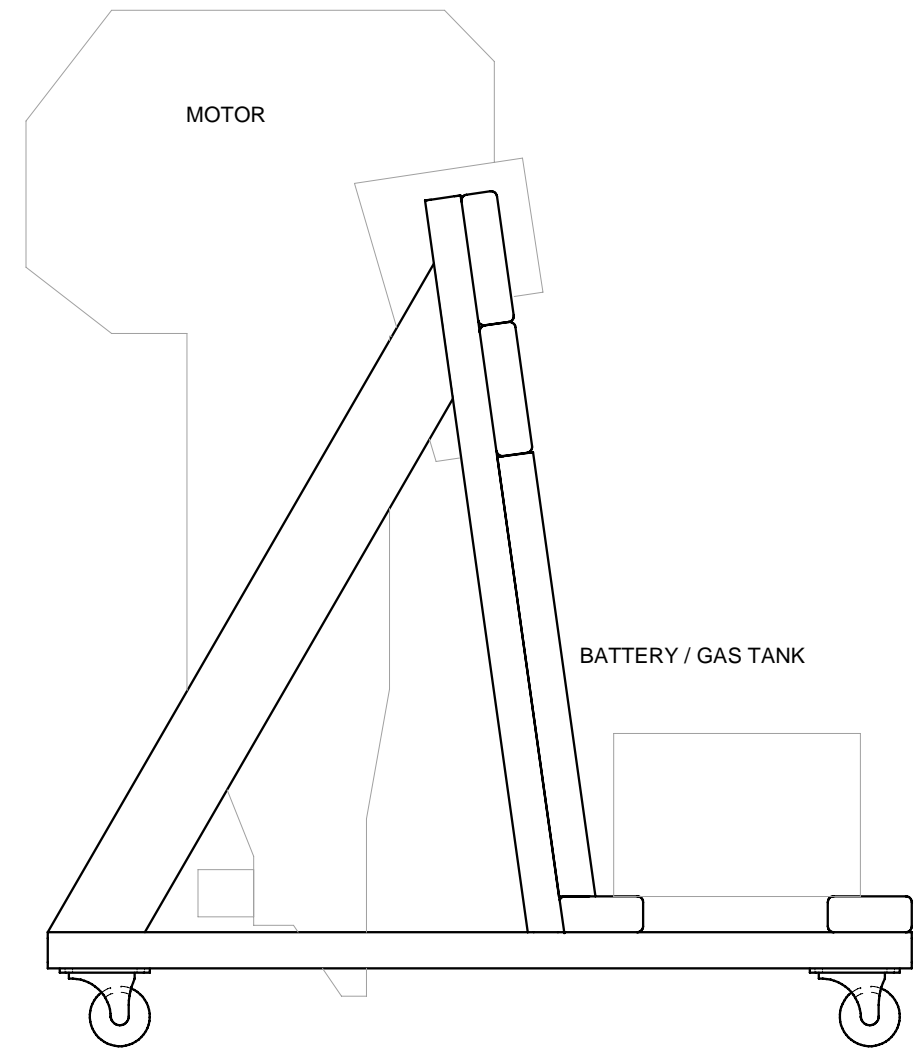

DRAWN: D. Hayes Jr	DATE: 7/21/2008
DESIGNED: D. Hayes Jr	DATE: 7/21/2008
CHECKED:	DATE:
APPROVED:	DATE:
G.C.:	DATE:

OUTBOARD MOTOR STAND

UNLESS OTHERWISE NOTED, ALL DIMENSIONS ARE IN INCHES.
DIMENSIONS ACCORDING TO ASME Y14.5M-1994 UNLESS OTHERWISE SPECIFIED.

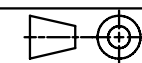

DRAWING:
Outboard Stand

SHEET:
1 of 6

REV:
-

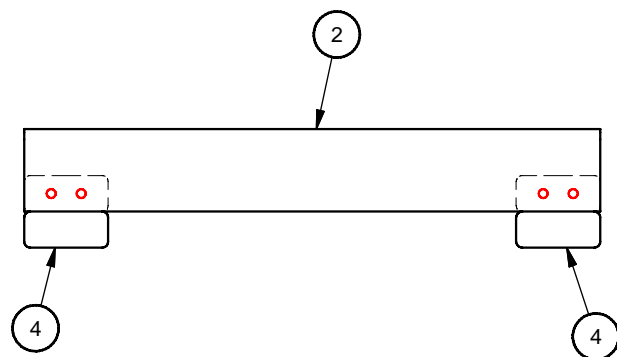
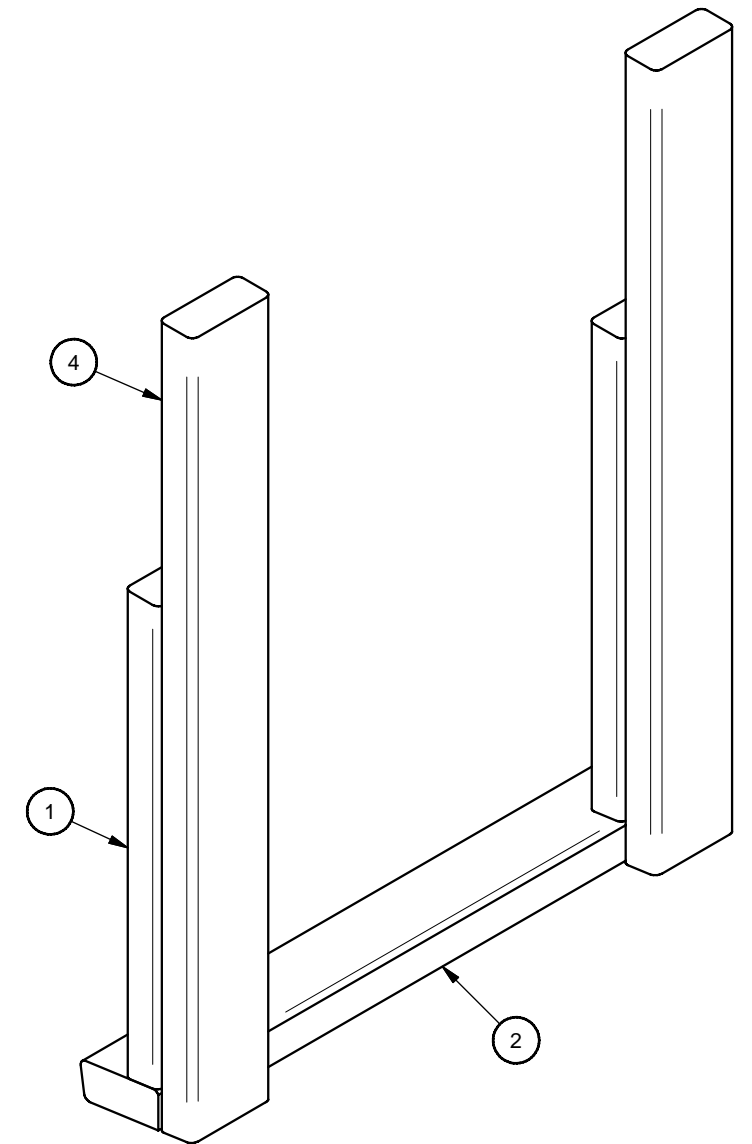
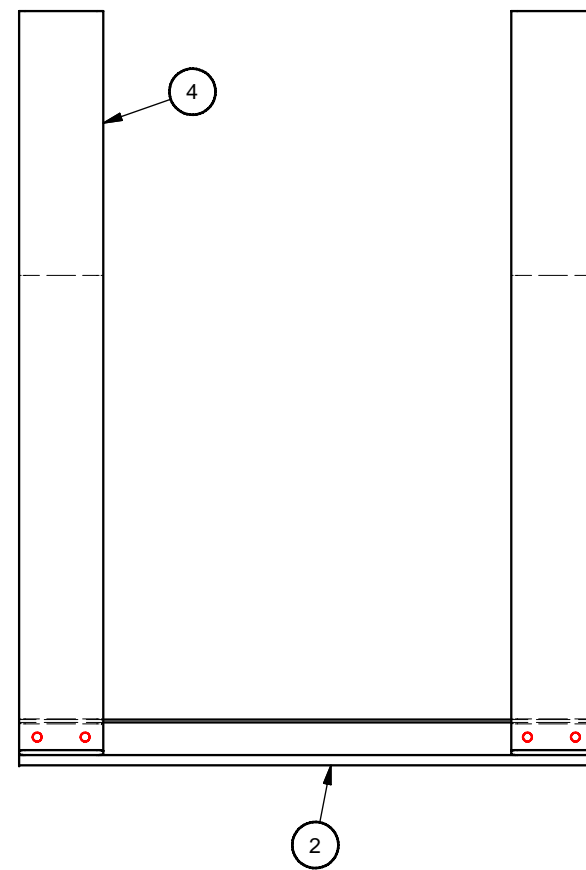
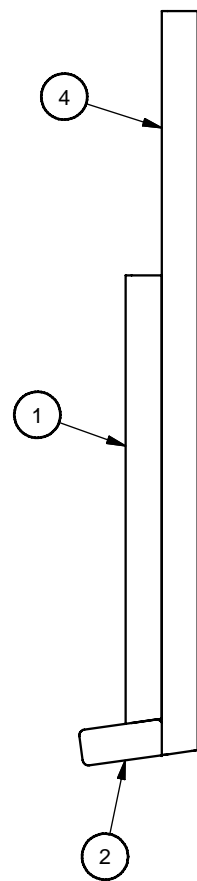
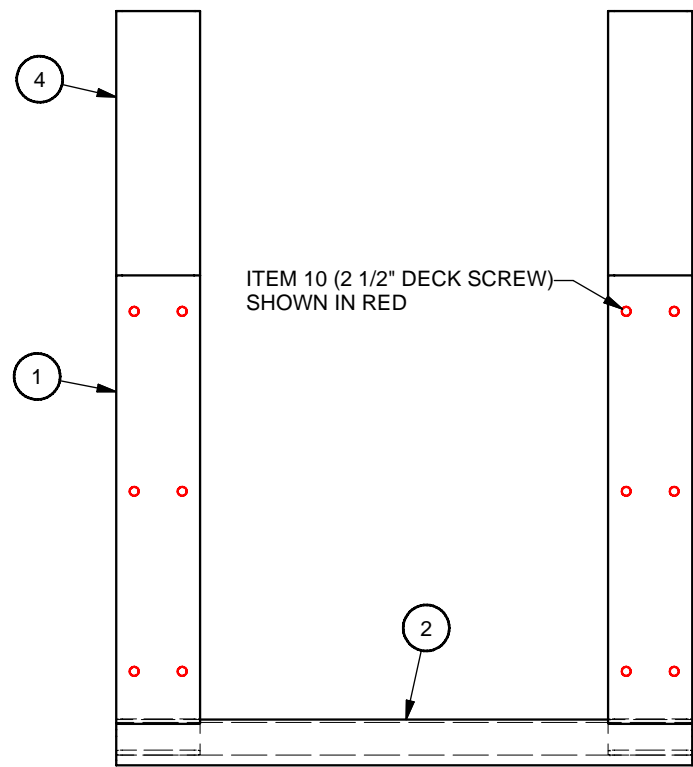

NOTES:
 1. DRY FIT 2X6 (PART E) TO ENSURE PROPER FIT WITH 2X4X18 11/6" (PART B).
 2. PRE-DRILL ALL SCREW LOCATIONS TO PREVENT WOOD FROM SPLITTING.

DRAWN: D. Hayes Jr	DATE: 7/21/2008
DESIGNED: D. Hayes Jr	DATE: 7/21/2008
CHECKED:	DATE:
APPROVED:	DATE:
Q.C.:	DATE:

UNLESS OTHERWISE NOTED, ALL DIMENSIONS ARE IN INCHES.
 DIMENSIONS ACCORDING TO ASME Y14.5M-1994 UNLESS OTHERWISE SPECIFIED.

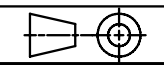

OUTBOARD MOTOR STAND (STEP 1)

DRAWING: Outboard Stand	SHEET: 2 of 6	REV: -
----------------------------	------------------	-----------

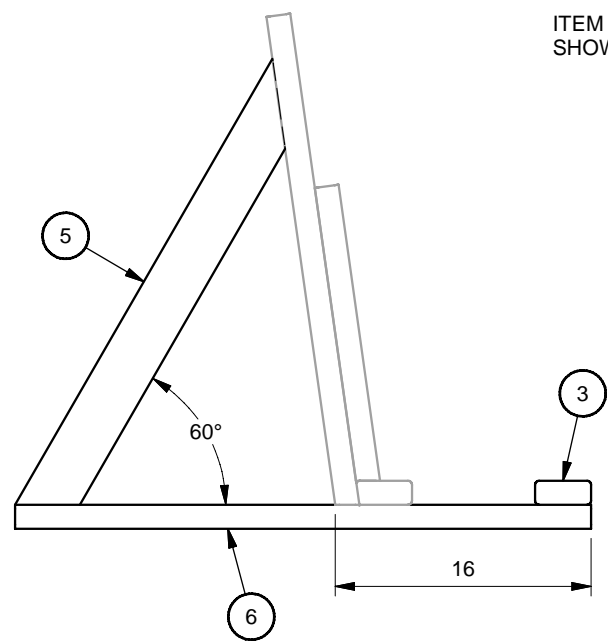
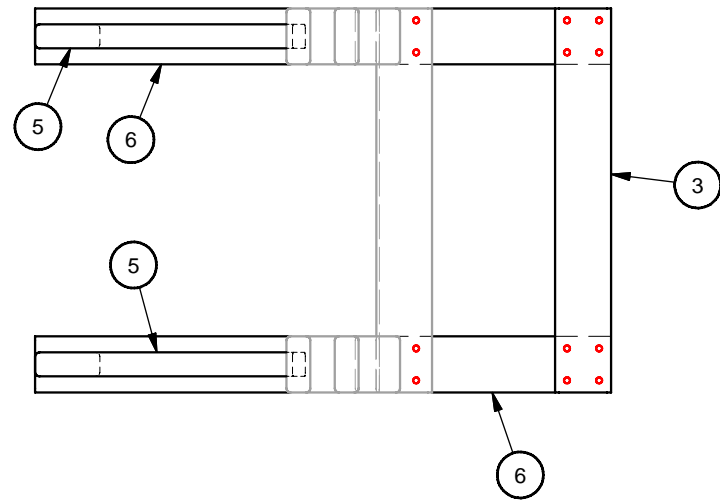

ITEM 10 (2 1/2" DECK SCREW)
SHOWN IN RED

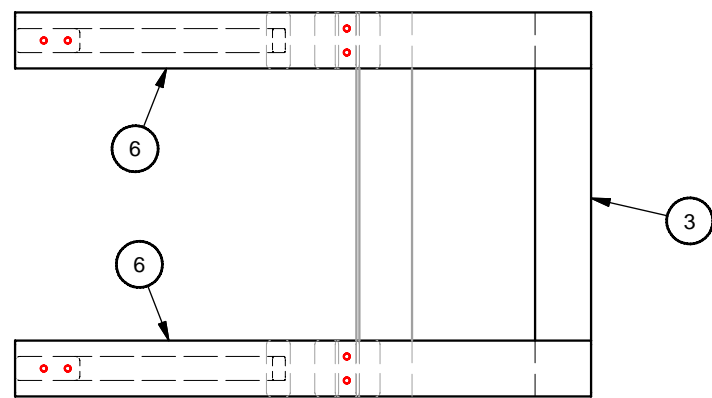
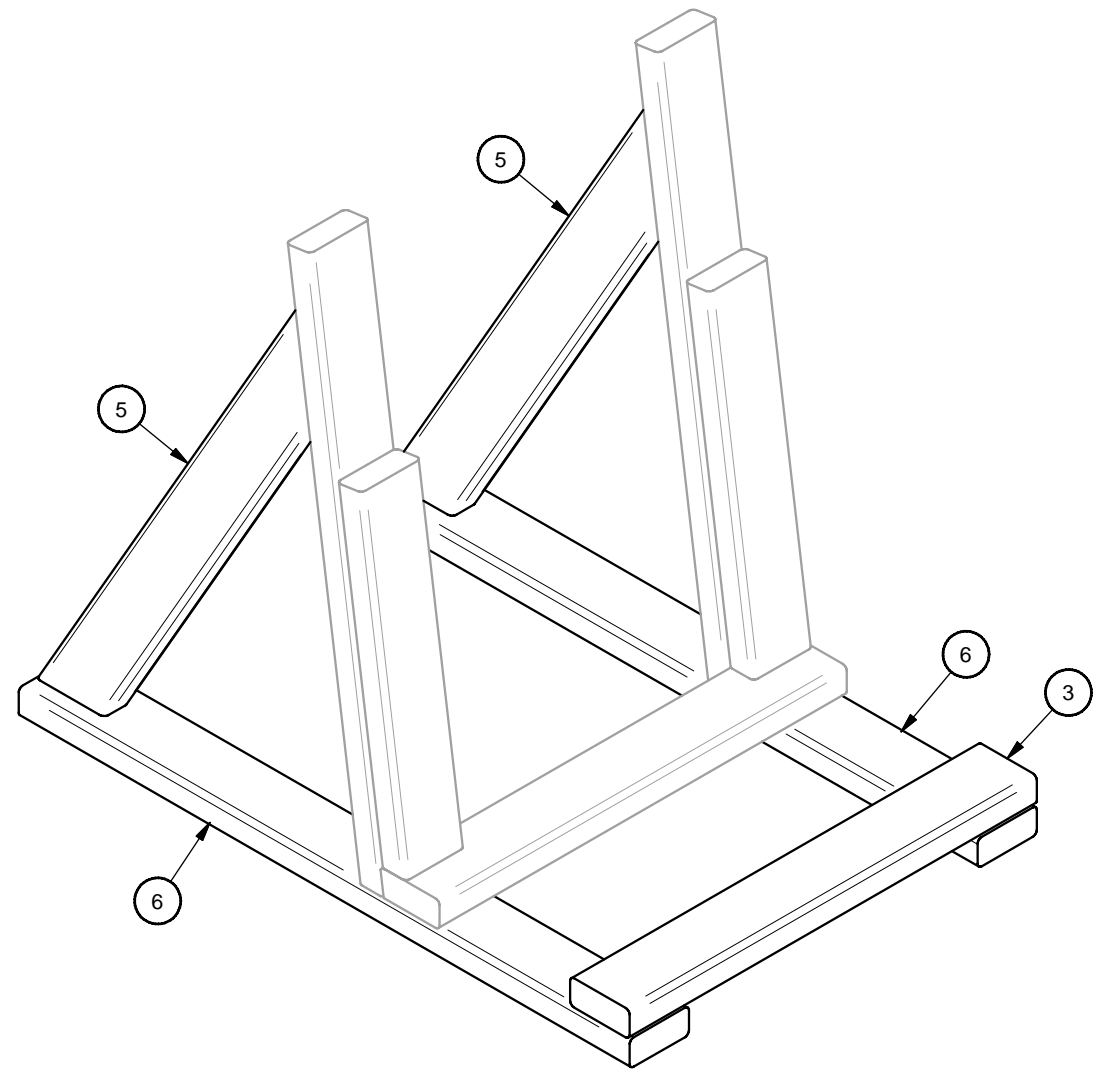
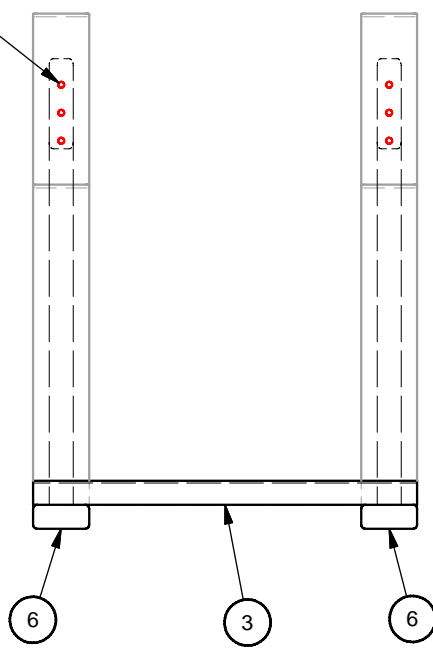

NOTES:
1. PRE-DRILL ALL SCREW LOCATIONS TO PREVENT WOOD FROM SPLITTING.

DRAWN: D. Hayes Jr	DATE: 7/21/2008
DESIGNED: D. Hayes Jr	DATE: 7/21/2008
CHECKED:	DATE:
APPROVED:	DATE:
G.C.:	DATE:

OUTBOARD MOTOR STAND (STEP 2)

UNLESS OTHERWISE NOTED, ALL DIMENSIONS ARE IN INCHES.
DIMENSIONS ACCORDING TO ASME Y14.5M-1994 UNLESS OTHERWISE SPECIFIED.

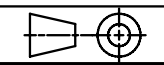

DRAWING: Outboard Stand	SHEET: 3 of 6	REV: -
----------------------------	------------------	-----------

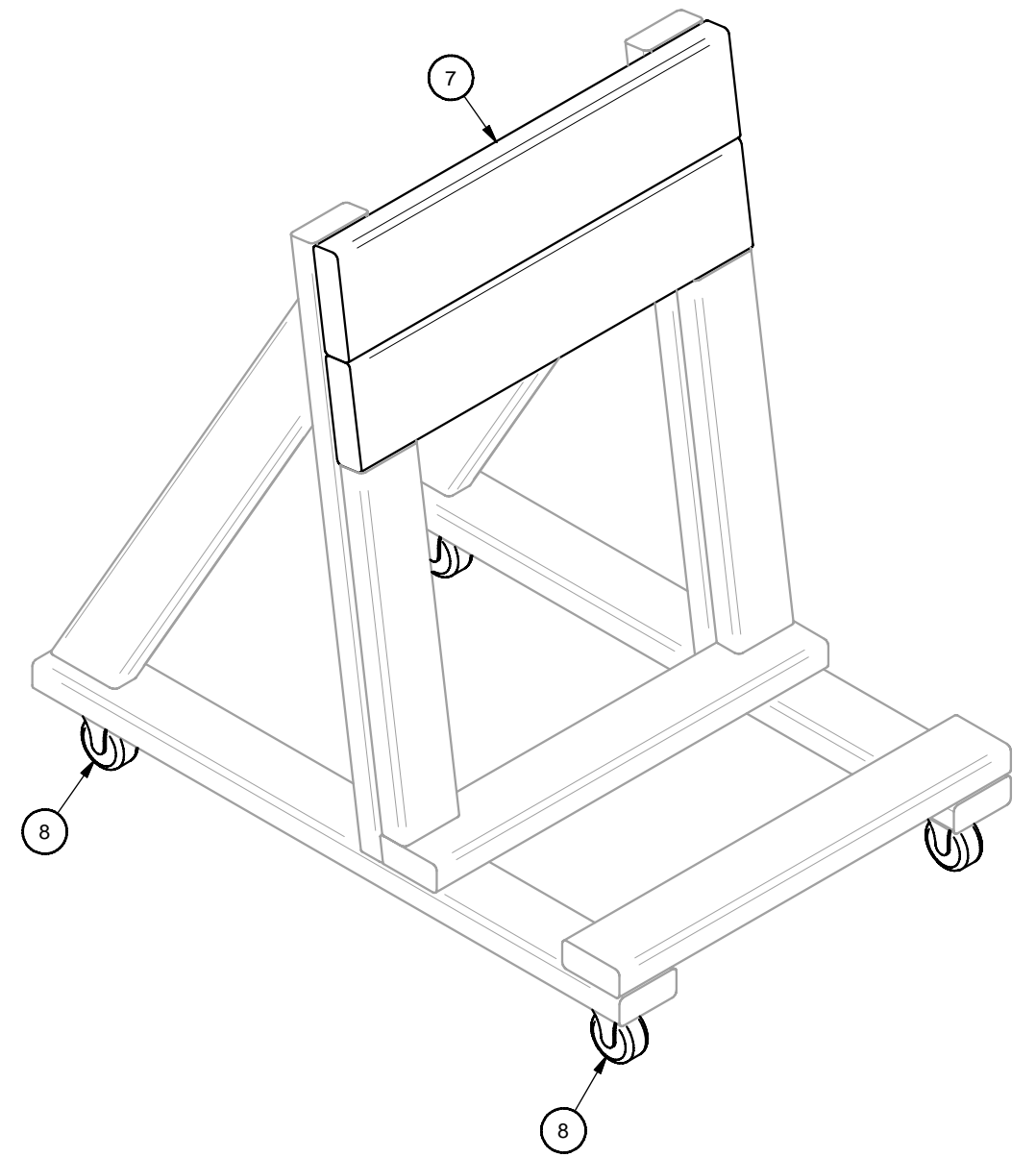
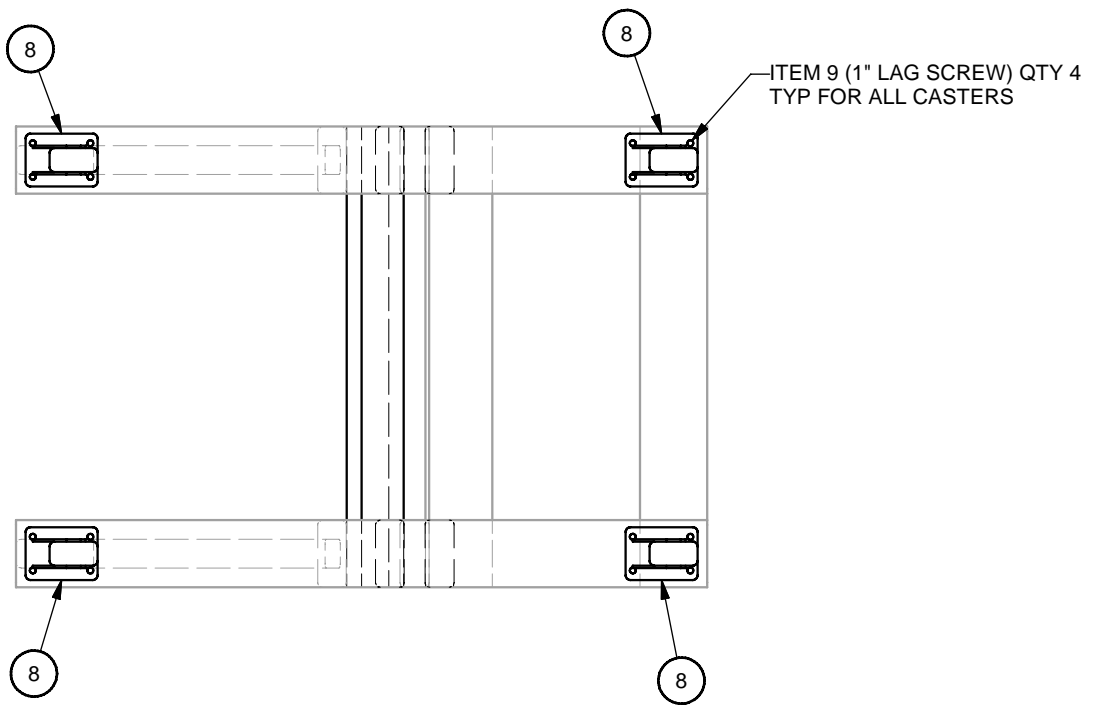
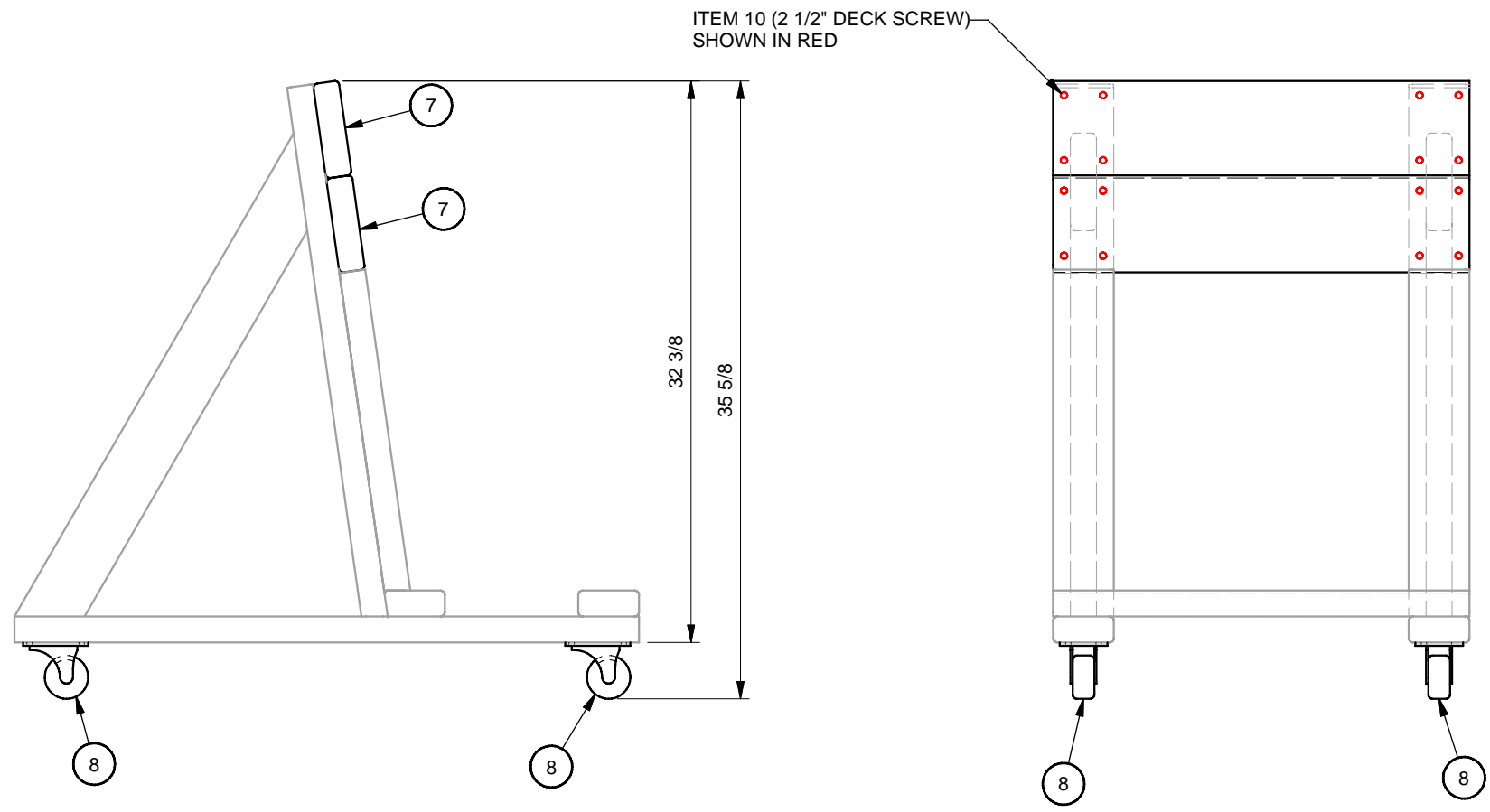

NOTES:
1. PRE-DRILL ALL SCREW LOCATIONS TO PREVENT WOOD FROM SPLITTING.

DRAWN: D. Hayes Jr	DATE: 7/21/2008
DESIGNED: D. Hayes Jr	DATE: 7/21/2008
CHECKED:	DATE:
APPROVED:	DATE:
Q.C.:	DATE:

OUTBOARD MOTOR STAND
(STEP 3)

UNLESS OTHERWISE NOTED, ALL DIMENSIONS ARE IN INCHES.
DIMENSIONS ACCORDING TO ASME Y14.5M-1994 UNLESS OTHERWISE SPECIFIED.

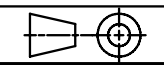

DRAWING: Outboard Stand	SHEET: 4 of 6	REV: -
----------------------------	------------------	-----------

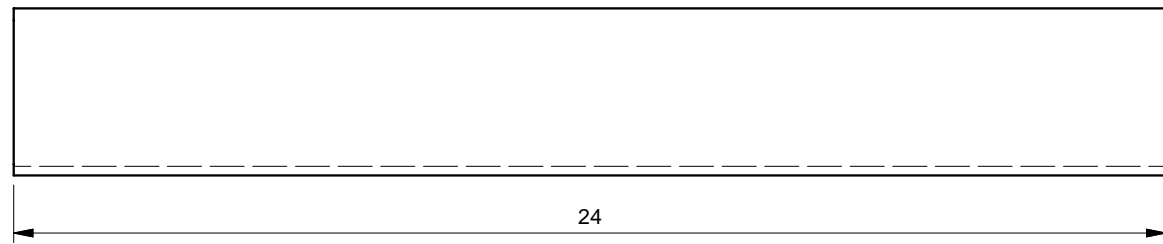

PART B

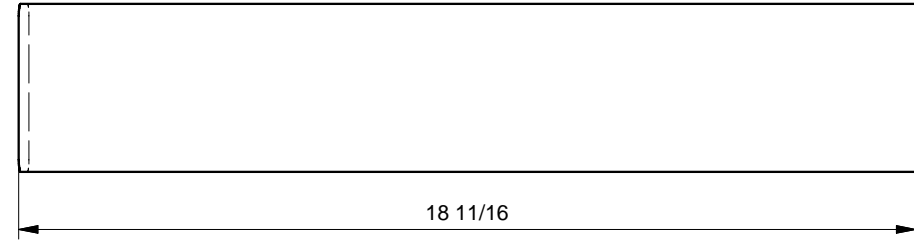
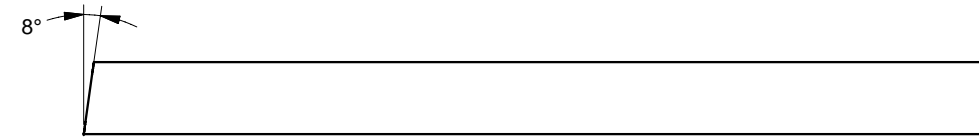
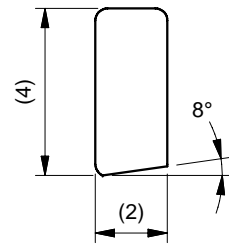

PART A

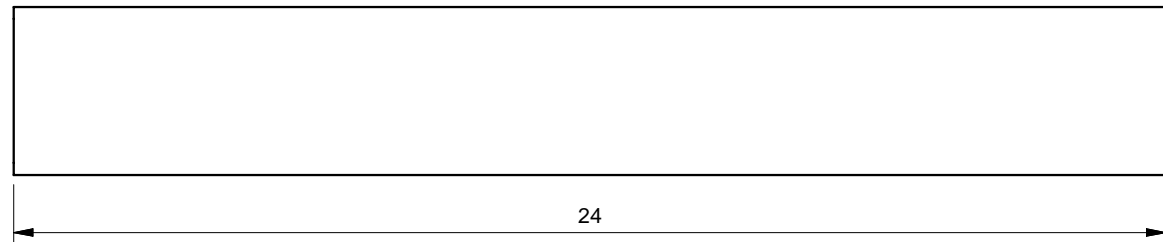
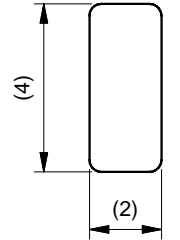

PART C

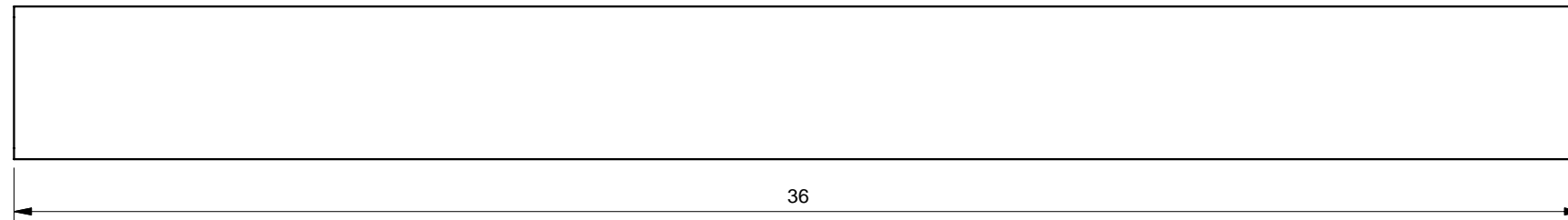
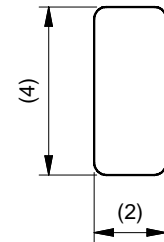

PART F

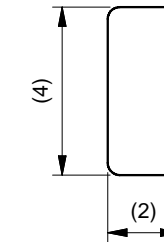

DRAWN: D. Hayes Jr	DATE: 7/21/2008
DESIGNED: D. Hayes Jr	DATE: 7/21/2008
CHECKED:	DATE:
APPROVED:	DATE:
Q.C.:	DATE:

OUTBOARD MOTOR STAND
(PARTS LAYOUT)

UNLESS OTHERWISE NOTED, ALL DIMENSIONS ARE IN INCHES.
DIMENSIONS ACCORDING TO ASME Y14.5M-1994 UNLESS OTHERWISE SPECIFIED.



DRAWING: Outboard Stand	SHEET: 5 of 6	REV: -
----------------------------	------------------	-----------

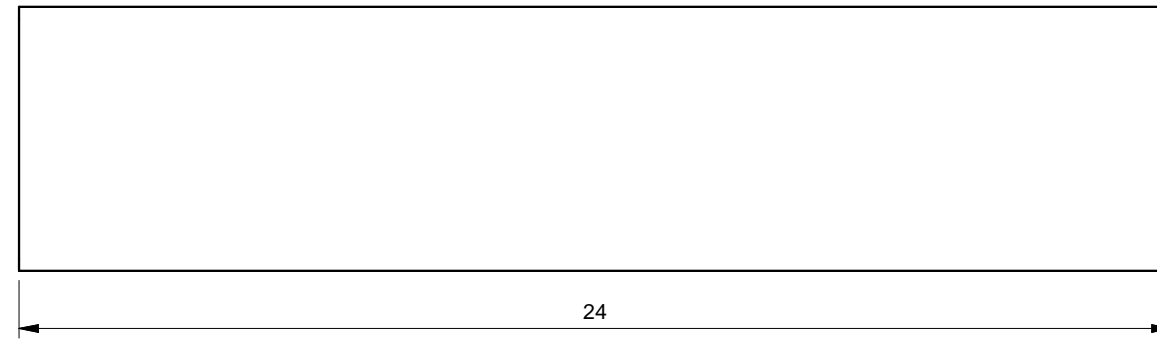

PART G

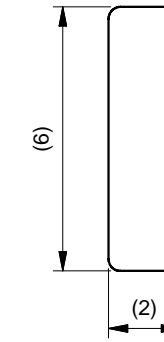

PART D

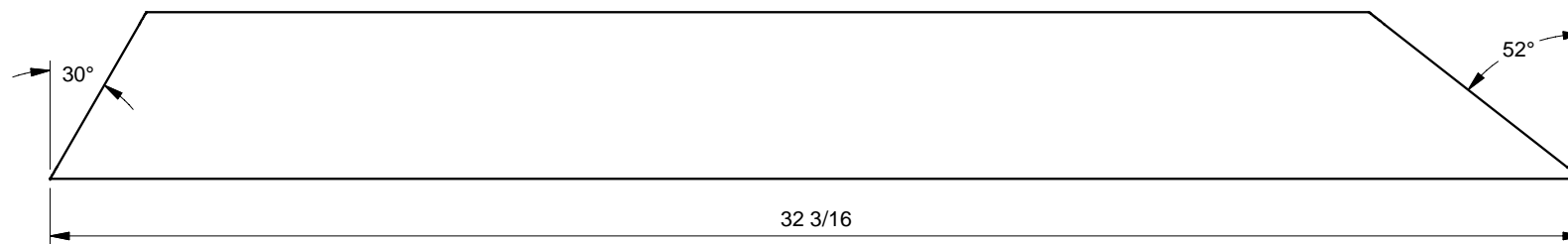
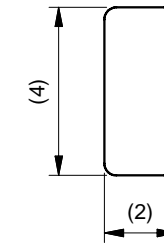

Part E

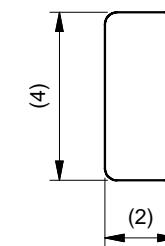

DRAWN: D. Hayes Jr	DATE: 7/21/2008
DESIGNED: D. Hayes Jr	DATE: 7/21/2008
CHECKED:	DATE:
APPROVED:	DATE:
Q.C.:	DATE:

OUTBOARD MOTOR STAND
(PARTS LAYOUT)

UNLESS OTHERWISE NOTED, ALL DIMENSIONS ARE IN INCHES.
DIMENSIONS ACCORDING TO ASME Y14.5M-1994 UNLESS OTHERWISE SPECIFIED.

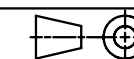

DRAWING: Outboard Stand

SHEET: 6 of 6

REV: -